

IGS®



# Monkey Paradise

## Operations Manual



# CONTENTS

About this Manual .....	2
Safety Notice .....	3
1.Quick Installation .....	5
1.1 Operation Recommendations .....	5
1.2 How to make connections .....	5
1.3 Machine Setup .....	7
1.4 Precautions .....	8
2.Machine Introduction .....	9
2.1 Packed Materials.....	9
2.2 Machine Overview.....	9
2.3 Machine Components .....	12
3.Installation and Disassembly .....	14
3.1 Machine transportation.....	14
3.2 Machine positioning .....	15
3.3 Link machine assembly instructions.....	16
1. Light box maintenance.....	16
2. Buttons and semicircular Buttons light replacement .....	17
3. Bulb and acrylic replacement .....	18
4. Ticket/Coin box operation methods.....	18
5. Main board maintenance.....	20
6. Internal hardware repair & replacement .....	21
7. Link machine assembly .....	23
8. Link light box assembly .....	23
9. Decoration signboard assembly.....	24
10. Central signboard light replacement .....	25
11. Left/Right fluorescent light tube replacement.....	27

4. About the game .....	28
4.1 Game introduction .....	28
4.2 How to play .....	29
5. Operator menu .....	31
5.1 How to use Operator Menu .....	31
5.2 Hardware Test .....	33
5.2.1 I/O Test .....	34
5.2.2 Sound Test .....	35
5.2.3 Light Test .....	36
5.2.4 Ticket Machine Test .....	37
5.2.5 Screen Test .....	38
5.2.6 Counter Test .....	39
5.2.7 Switch Table .....	40
5.2.8 Lan Test .....	41
5.3 System Setting .....	42
5.3.1 Game Setting .....	46
5.3.2 Time Setting .....	47
5.3.3 System Reset .....	48
6. Q&A Troubleshooting .....	49
7. Repair & Maintenance .....	50
7.1 Clean-up & Maintenance .....	50
Appendix: Machine Wiring Diagram .....	51



## About this Manual

This **《Operator Manual》** describes how to install, set up and use this product. It is intended to instruct operator and maintenance personnel to safely and correctly operate the machine. Make sure to follow all the safety and warning instructions described in this manual to prevent injury or damage to the machine.

Non-qualified personnel should not perform maintenance or repair. Qualified technicians refer to people in possession of high school (or above) degree in mechanic/electric engineering or the equivalent, and have engaged in routine maintenance and repair of the game machine.

Please keep this manual for future reference. Always read the manual carefully and provide instructions to personnel who are appointed to operate, move, transport, install, maintain or repair the machine.



### **Disclaimer**

---

IGS does not assume responsibility, either express or implied, for the correctness or completeness of this manual. Nor does IGS guarantee any merchantability or fitness for a particular purpose. IGS reserves the right to change this publication at any time without obligation to notify anyone of such revisions or changes.



### **Trademark**

---

IGS® is the trademark of International Games System Co., Ltd.

© Copyright 2009, International Games System Co., Ltd.

Reproduction of any part of this manual without prior written permission is prohibited.



# Safety Notice

## General

---

- DO NOT disassemble, change and modify the machine without authorization.
- Make sure to operate the machine as instructed by this manual. Inappropriate handling of the machine will cause damage to the machine and injury threat to players and spectators.
- Please check and maintain the machine regularly.
- Make sure that the warning labels are clean to be clearly read. If the label is too dirty to be clearly read, replace a new label immediately.



CAUTION

## Installation Sites

---

- This machine is designed for indoor use. DO NOT place it outdoors. Make sure the machine is not installed in the following venues:
  - Place of direct sunlight exposure, water contact, high humidity and high temperature.
  - Place where there is flammable and volatile chemicals and hazardous substances.
  - Place where the ground is sloping, uneven or there is strong vibration.
  - Place close to emergency exits and fire extinguishers.
- DO NOT obstruct the ventilation holes to avoid damage to the machine.
- Make sure the machine is separate from the wall, other machines and passages by at least 30 cm.



WARNING

## Power

---

- Before connecting the machine to the main supply, verify that the voltage is correct to avoid fires or electronics shock.
- When connecting the machine to the main supply, verify the main outlet is a grounded outlet.
- To avoid electronics shock and short circuit ,DO NOT run the power cord or ground wire across passages.
- To avoid fire,DO NOT place any flammable objects close to the power cord.



- In the event of frayed power cord, please contact your dealer for replacement.
- DO NOT use fuses or parts that are not recommended by IGS.
- To avoid electronics shock or short circuit:
  - Make sure to turn the power OFF before attempting maintenance or repair.
  - DO NOT touch the plug with damp hands.
  - Do not insert/unplug the power plug all of a sudden.
  - When plugging/unplugging the power cord, make sure to hold plug. DO NOT pull on the power cord.



WARNING

## **Transportation**

---

- During transportation, ensure that the castors are fasten.
- The machine contains a LCD monitor which is fragile; avoid strong vibration or rough handling during transportation.



CAUTION

## **Moving**

---

- Before moving the machine, make sure to unplug it from the main.
- When moving the machine, pay attention to obstructions and uneven surface to avoid accidents or damage to the machine.
- Make to move the machine with at least two personnel to avoid accident and injury.



CAUTION

## **During Operation**

---

- To avoid injury and accidents to players during operation, those following categories are not allowed to play the game:
  - People with high blood pressure or cardiovascular diseases
  - People who are injured or less mobile
  - Drunk people
- Instruct the players to read the warning labels and follow the instructions to prevent electronics shock or short circuit.



# 1. Quick Installation

## 1.1 Operation Recommendations

---

- If the average ticket out number per coin is set to be high, players get more tickets per coin on the average and the operators get more revenue.
- After the machine is reset, the win rate in the beginning will be enhanced; therefore, it is highly recommended that reset should only be done when necessary.
- To reset link machines, ensure that all of them are in the power-on status. Make sure the reset is done from the Server machine so as not to mess up the account data in different machines.

## 1.2 How to make connections

---

### 1. Connect machines using signal cable and Internet cable.

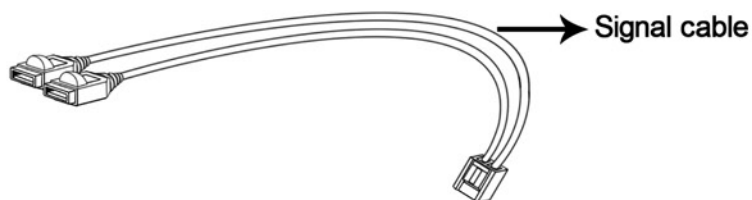
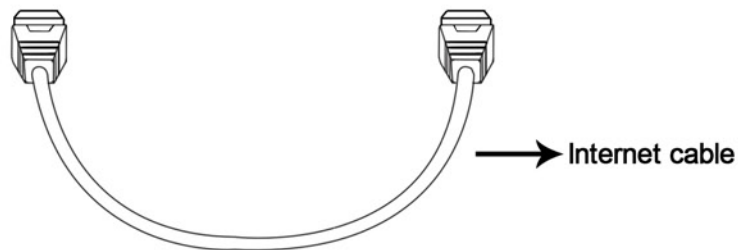



## 2. Make connections by the following steps:

(1). Insert the signal end of the signal cable to the board and the Internet end to the Internet port in the back of the power panel of the machine. Make sure the two ends are correctly inserted.

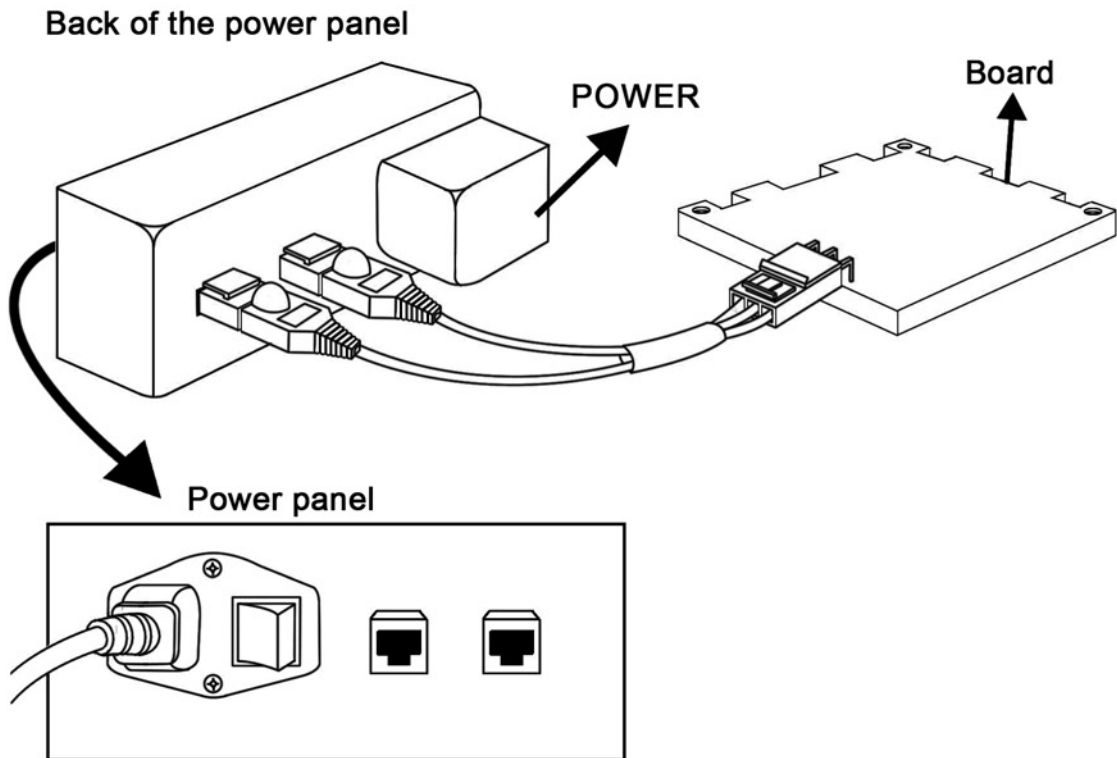

(2). Connect all machines using the Internet cable and the Internet ports beside the power switch. The max number of linked machine (including the Server) is 12.

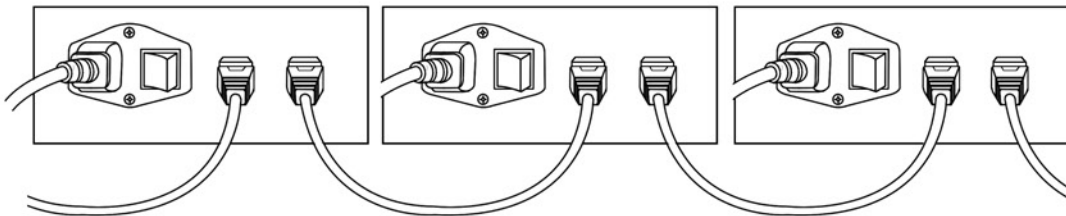





## 1.3 Machine Setup

### 1. Set the Server

This game supports up to 12 link machines, one of which should be set to be Server machine by turning PIN 1, 2, 3, and 4 of SW to be OFF.

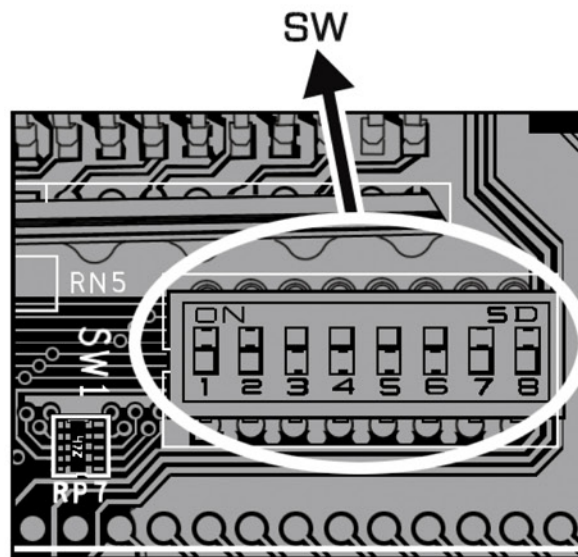

After DIP Switch Setting is done, power off the machines and move the toggle switch on the board to reset the settings. Then restart power on the machine again to bring the new settings effective.

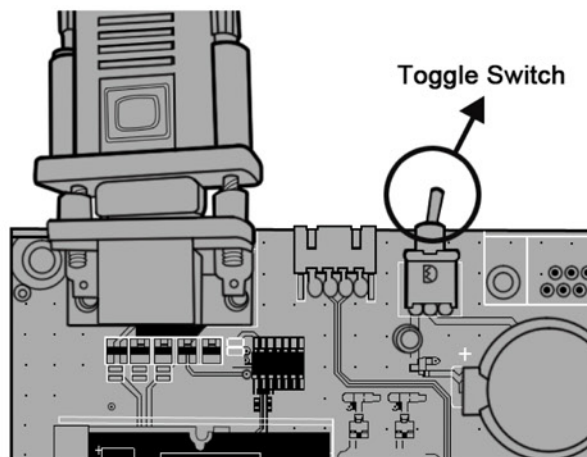

To check DIP Switch Setting, press Test Key on the machine to enter 『Operator Menu』. Select 『Hardware Test』 and enter 『Switch Table』.



## 2. Set the Clients

Set and give order to other linked machines by adjusting PIN 1-4 of their SW. After the DIP Switch Settings are done, power off the machine and reset it using toggle switch. Then restart power on the machine again to bring the new settings to be effective.

To check DIP Switch Setting, press Test Key on the machine to enter 『Operator Menu』. Select 『Hardware Test』 and enter 『Switch Table』.

## 3. Switch Table

DIP SW		1	2	3	4	5	6	7	8	Note
Server & Clients settings	No. 1 (Server)	OFF	OFF	OFF	OFF					Samba
	No. 2	ON	OFF	OFF	OFF					Reggae
	No. 3	OFF	ON	OFF	OFF					White
	No. 4	ON	ON	OFF	OFF					Samba
	No. 5	OFF	OFF	ON	OFF					Reggae
	No. 6	ON	OFF	ON	OFF					White
	No. 7	OFF	ON	ON	OFF					Samba
	No. 8	ON	ON	ON	OFF					Reggae
	No. 9	OFF	OFF	OFF	ON					White
	No. 10	ON	OFF	OFF	ON					Samba
	No. 11	OFF	ON	OFF	ON					Reggae
	No. 12	OFF	OFF	ON	ON					White

## 1.4 Precautions

After the above settings are done, machines are ready to be linked.

Please take notice of the followings when you make connections:

- 『System Setting』 can only be done from the Server machine.
- System will reset automatically when you adjust Av. Ticket-out Rate Per Coin and Coin Rate under 『System Setting』; however, these changes do not affect the adjusted values. To restore default values, please enter 『Operator Menu』 from the Server to conduct system reset.



# 2. Machine Introduction

## 2.1 Packed Materials

---

After you purchased this product, make sure your package come in with the following kits. In the event of any missing or broken items, please contact your local dealer.

### Kits for single machines

Content	Quantity	Note
Power cord (3P)	1	
Keys -5438	1	
Keys—5350	1	

### Kits for set machines (including 3 machines and 1 link signboard)

Content	Quantity	Note
Power cord (3P)	3	
Keys -5438	2	
Keys—5350	1	
M6*40 Wing Screw	6	
M6 Wing Nut	6	
M5*30 Flat Philip Screw	2	
RJ45 Cable	3	

## 2.2 Machine Overview

---

### Machine Information

- Power voltage: AC110V~120V / AC220V~240V (50~60HZ)  
Plug according to the indicated Voltage
- Maximun Power consumption: 150W
- Machine Dimension: W2110xD610xH2390 mm(Set with upper lid)
- Machine Weight : 225Kg(Set with upper lid)



## Machine View & Dimensions (single machine)

### 3 Machine Views & Dimensions (single machine)

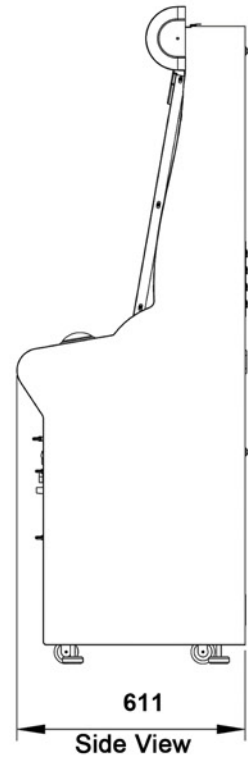
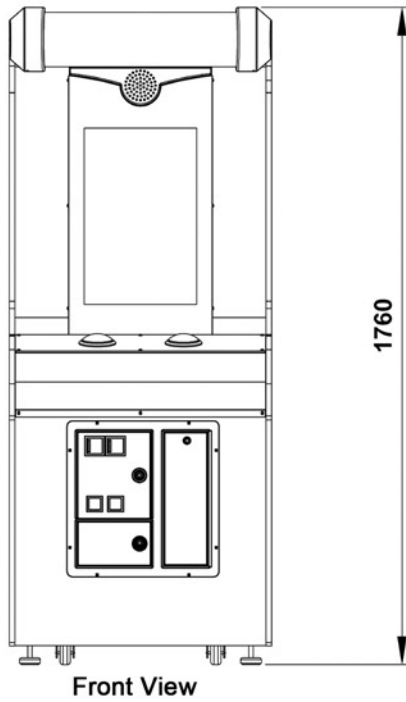
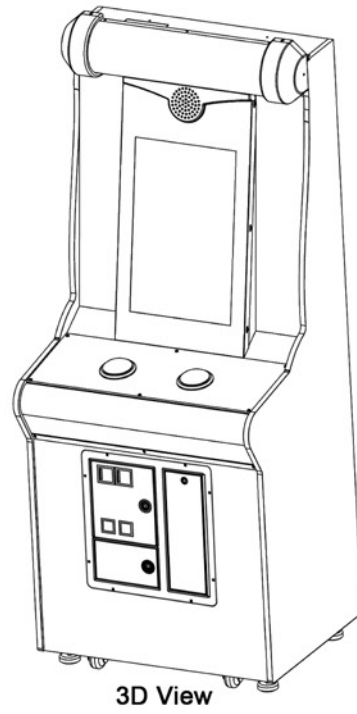
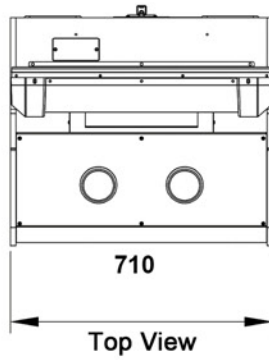

Note: Please make sure if the power is Voltage before inserting the power cord.



## Machine View & Dimensions (Link machines)

### 3 Machine Views & Dimensions (3 link machines)

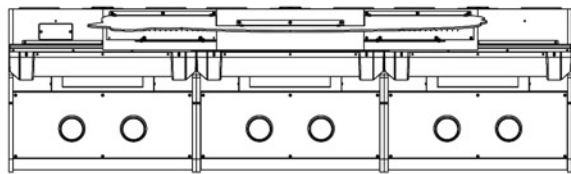

Top View

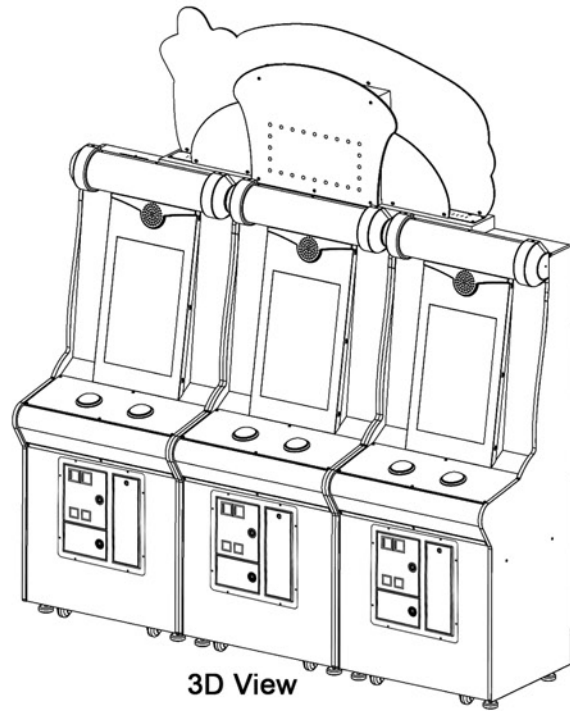

3D View

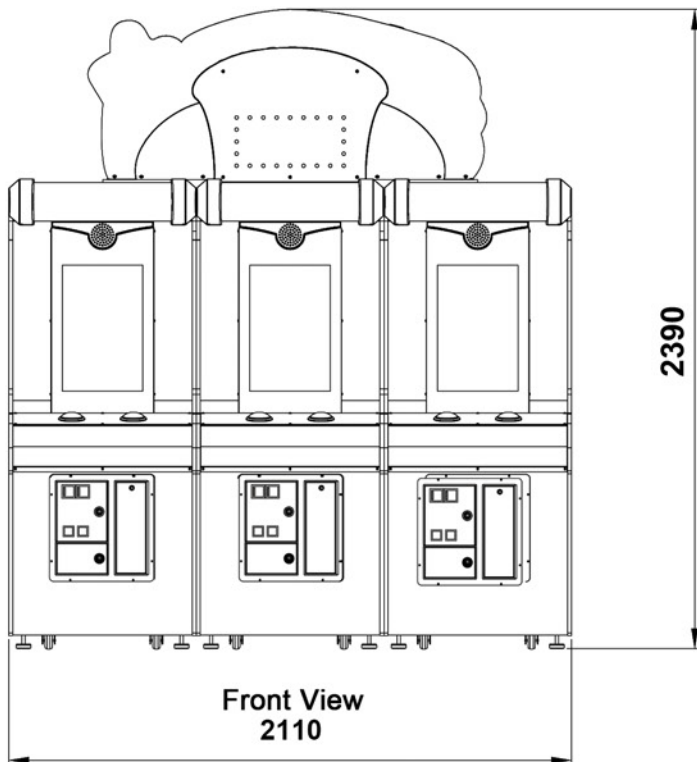

Front View  
2110

2390

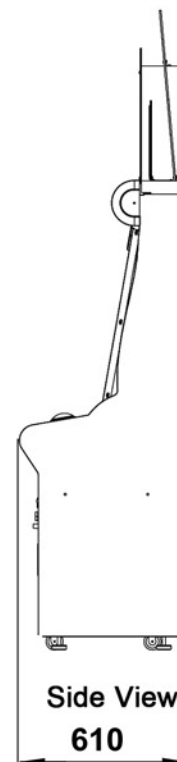

Side View  
610



## 2.3 Machine Components

---

### 1. Parts Description

#### Overview

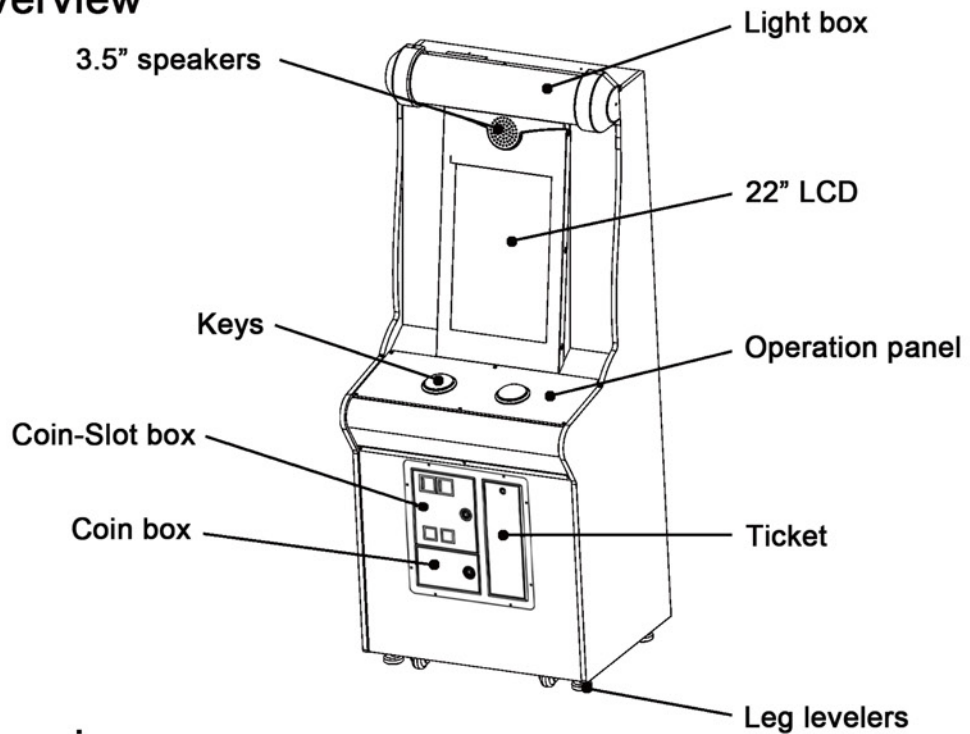

#### Overview

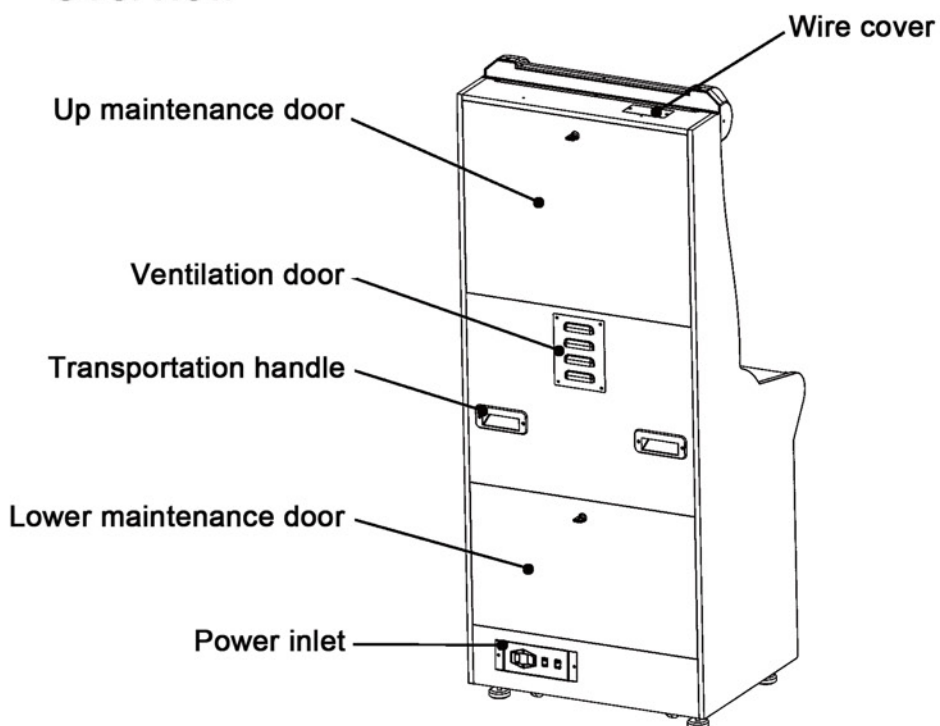



## Linked machine overview

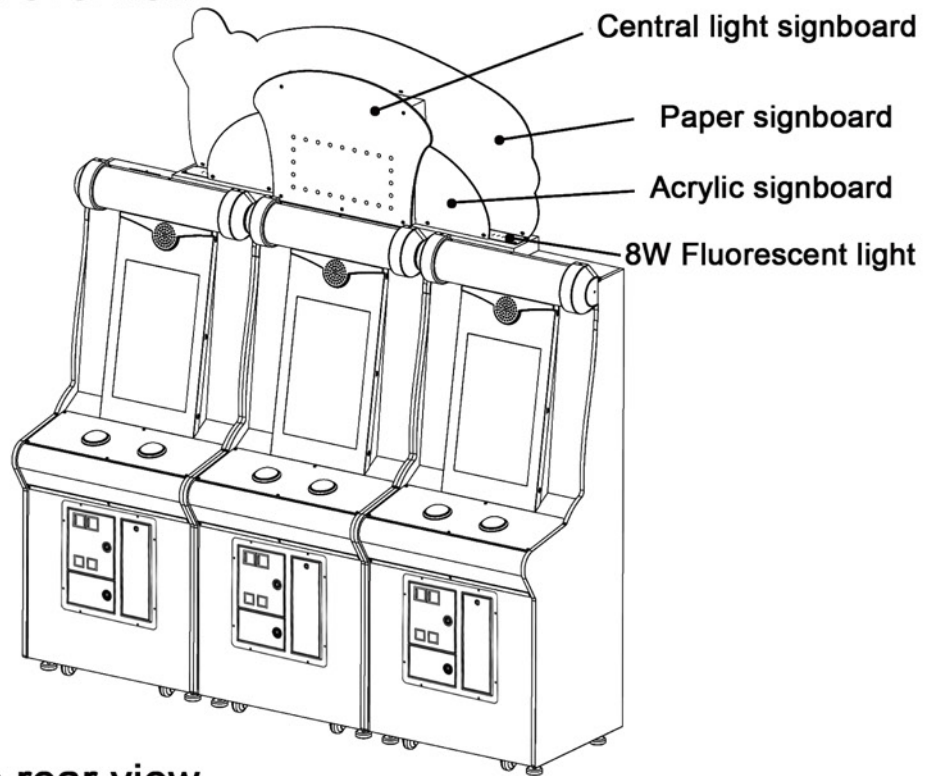

## Link machine rear view

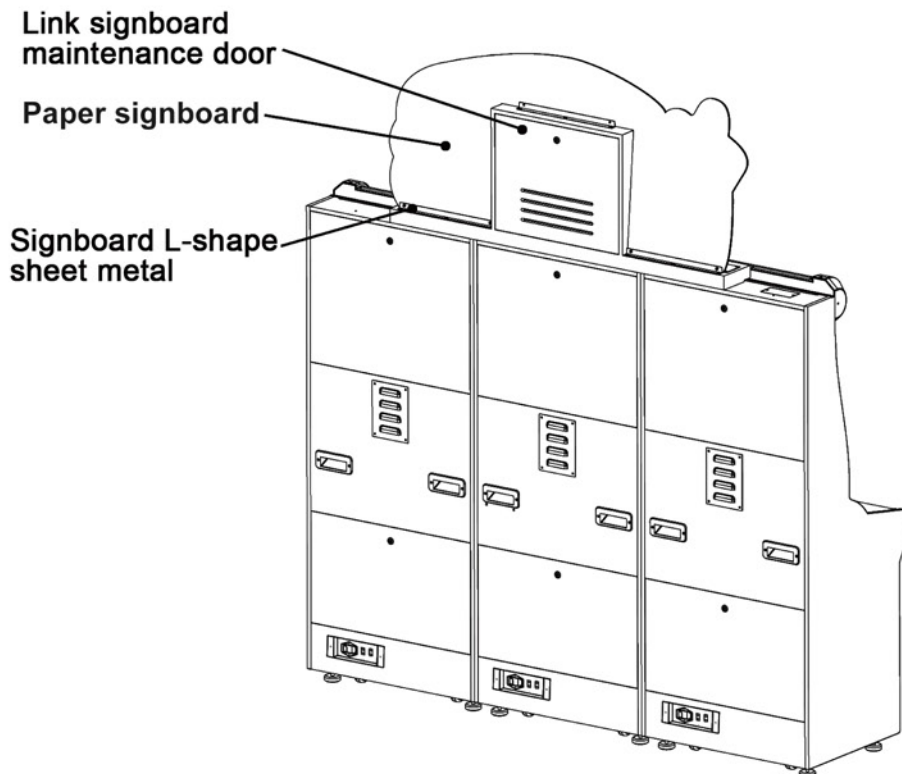



# 3. Installation and Disassembly

## 3.1 Machine transportation

---

After you purchase this product, please move the machine to the installation location and then connect the wires. Please make sure you follow the instructions to move and select an installation location.



---

### Transportation precautions

- Transporting machines with forklifts, make sure the point of force is applied so as to avoid accidents or machine damage.
  - Transporting machines on a vehicle, make sure they are fixed steadily on the vehicle from the wheels so as to avoid movement. DO NOT use leg levelers; otherwise, damage might be caused to the machine.
  - Note that LCD is a fragile item. Avoid strong vibration or shock.
- 



---

### Movement precautions

- To prevent accidents, please unplug the power cord before moving the machine.
  - When moving the machine, please ensure the blockage ahead is removed and the road surface is level so as to avoid accidents and machine damage.
  - When moving the machine, please ensure that task is carried out by at least two personnel so as to avoid accidents and machine damage.
-





#### Installation site precautions

- This machine is designed for indoor use. **DO NOT** install outdoor or any of the following locations:
  - Where there is direct sunlight exposure, water leakage, humidity and high temperature.
  - Where is close to flammable, volatile and hazardous substances.
  - Where is tilted, shaky or of frequent vibration.
  - Where is close to emergency exit or fire prevention equipment such as fire extinguishers.
- On the bottom of the machine is the ventilation door where the main machine and monitor vents its heated air. **DO NOT** place any objects in front of the ventilation door to prevent any machine failure.
- Keep this machine at least 30cm away from the walls, other equipment, and passages.

## 3.2 Machine positioning

Please use the leg leveler at the bottom of the machine to fix the machine. Move the leveler counterclockwise to adjust its distance to be at least 5mm from the ground.

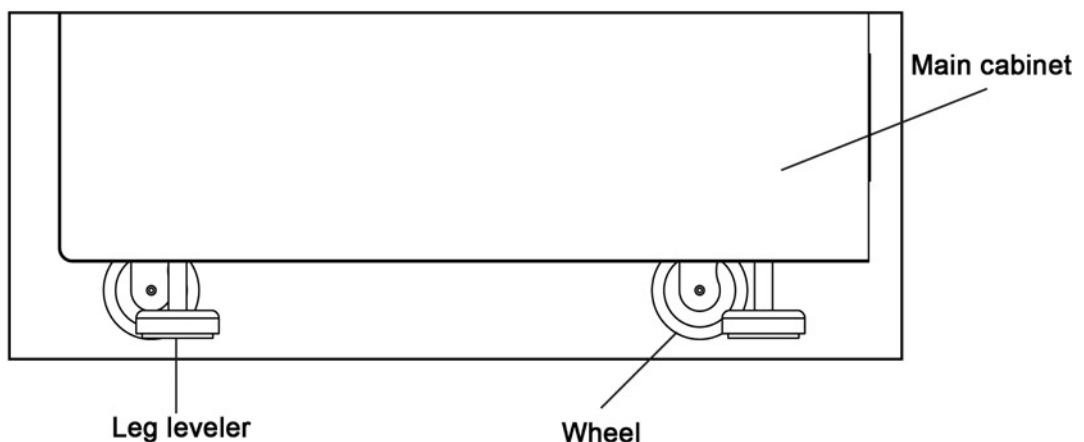



### 3.3 Link machine assembly instructions

---

#### 1. Light box maintenance

Step 1: Remove the maintenance door at the back of the machine by using a key.

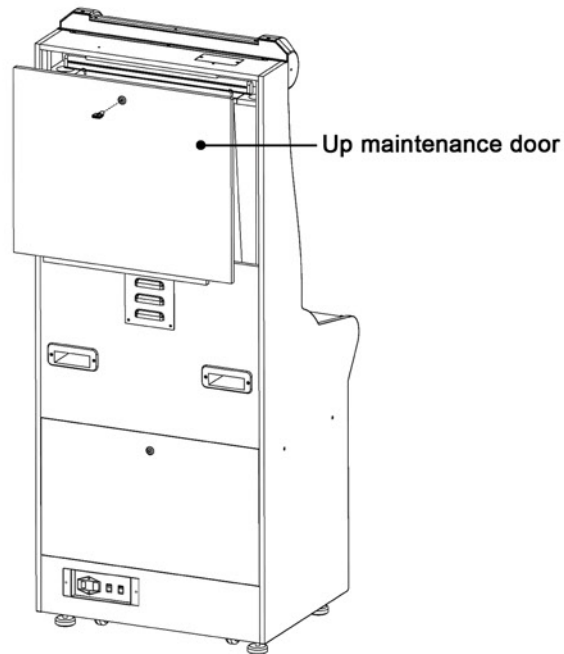

Step 2: Remove the used fluorescent light tube and replace with a new one.

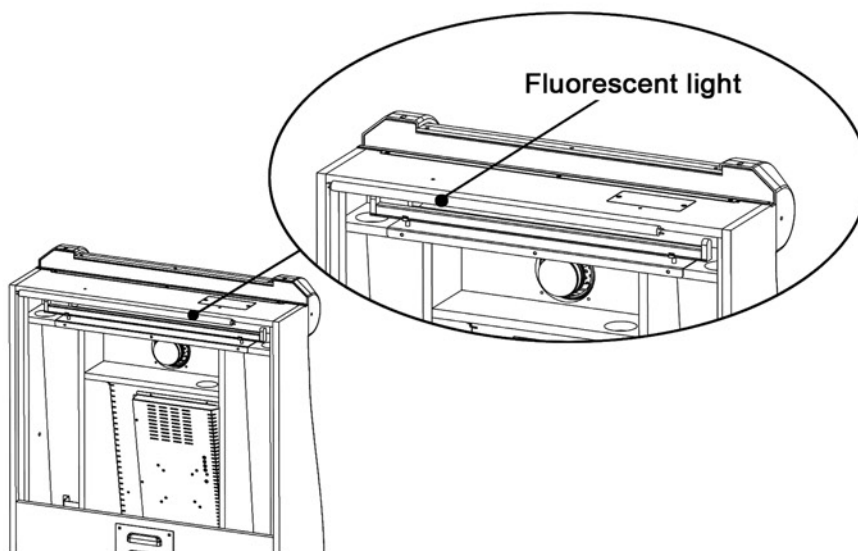



## 2. Buttons and semicircular Buttons light replacement

Step 1: Remove six M5 screws on acrylic of the operation panel and the Buttons signal cable.

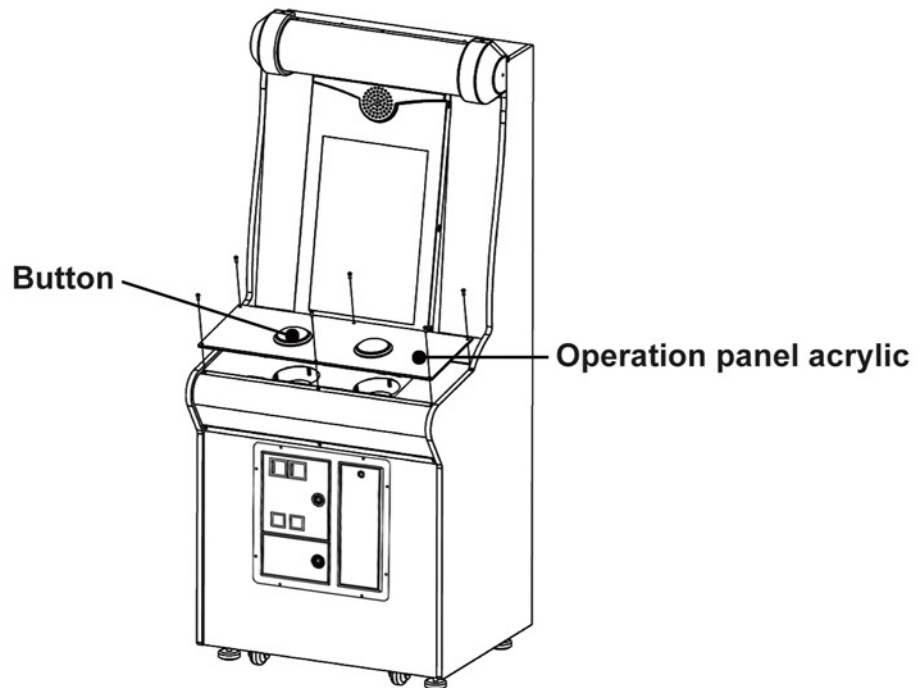

Buttons repair: If the light bulb fails, replace the used one with a new one. If the Buttons fails, please remove the light base and loosen the plastic screw nut to replace the Buttons.

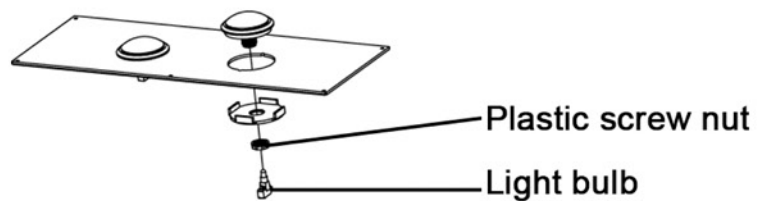

### 3. Bulb and acrylic replacement

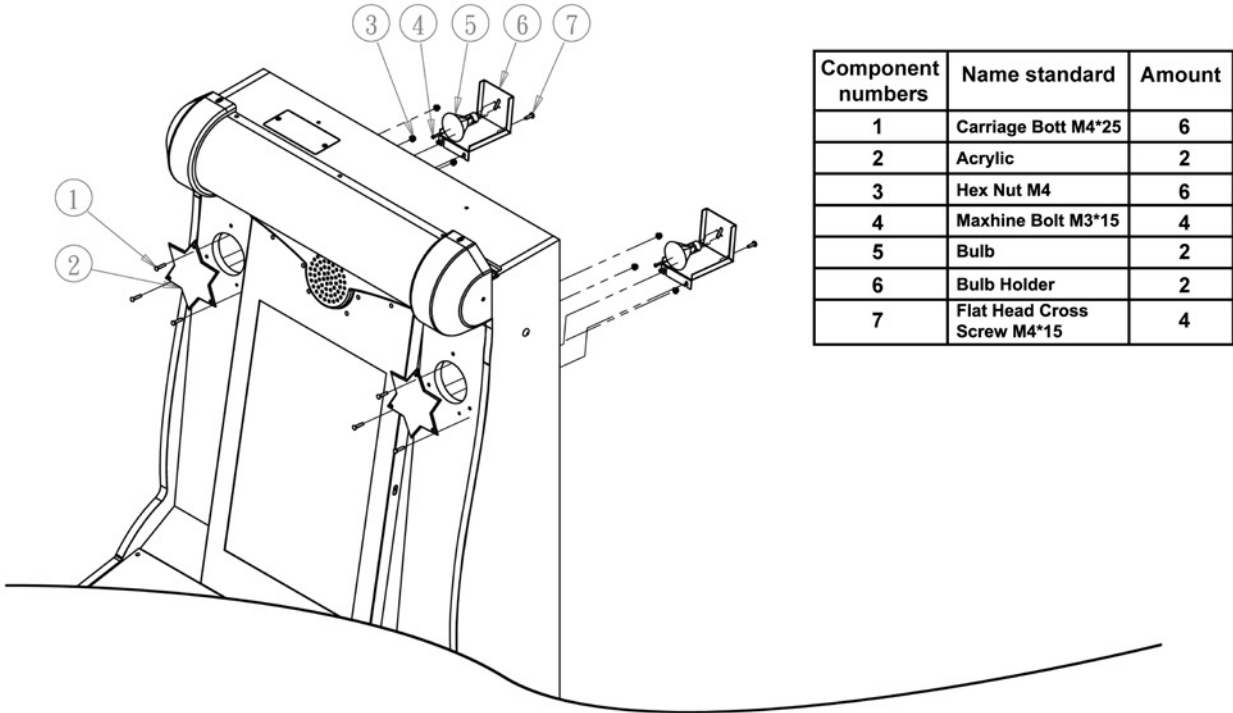

### 4. Ticket/Coin box operation methods

Step 1: Insert keys.

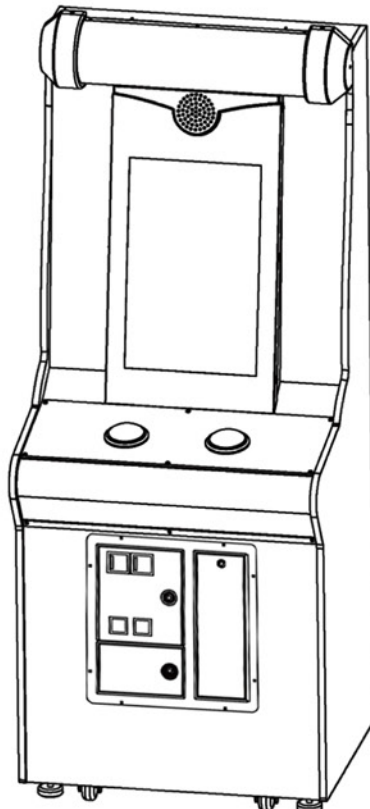



Step 2: Open the box to change tickets or coins, use Service Key and Test Key, as well as to check coin and ticket counter.

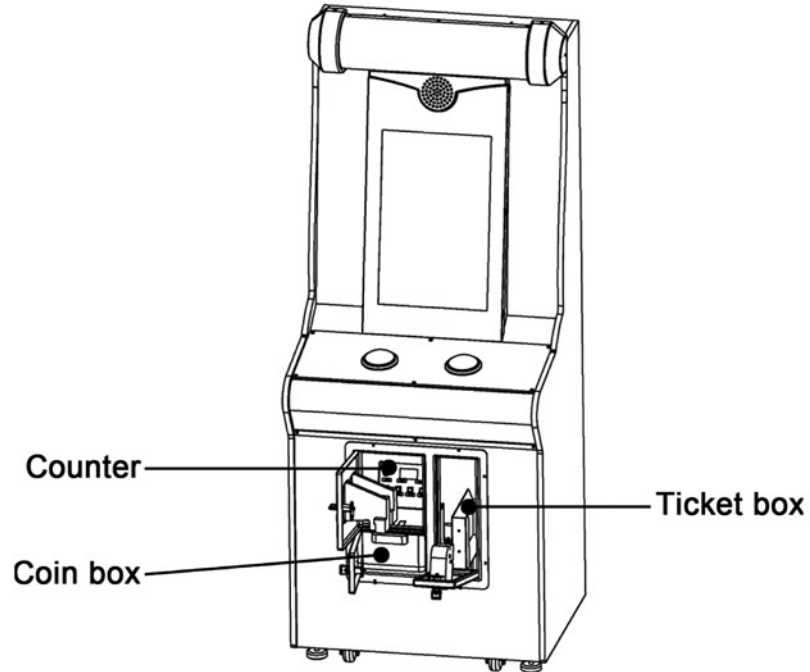

Coin box operation panel illustration:

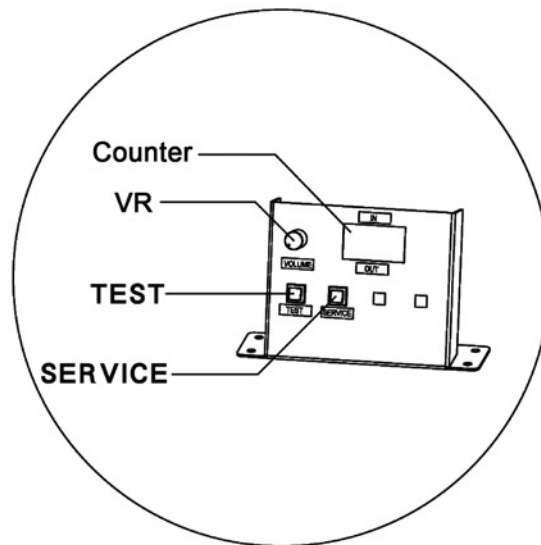



## 5. Main board maintenance

Step 1: Remove the maintenance door at the back of the machine by using a key.

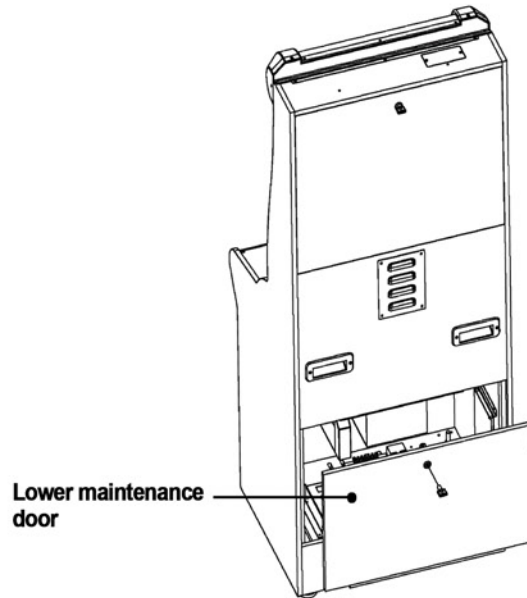

Step 2: Remove four M3 screws on the fixing sheet metal of the main board and then maintenance the main board.

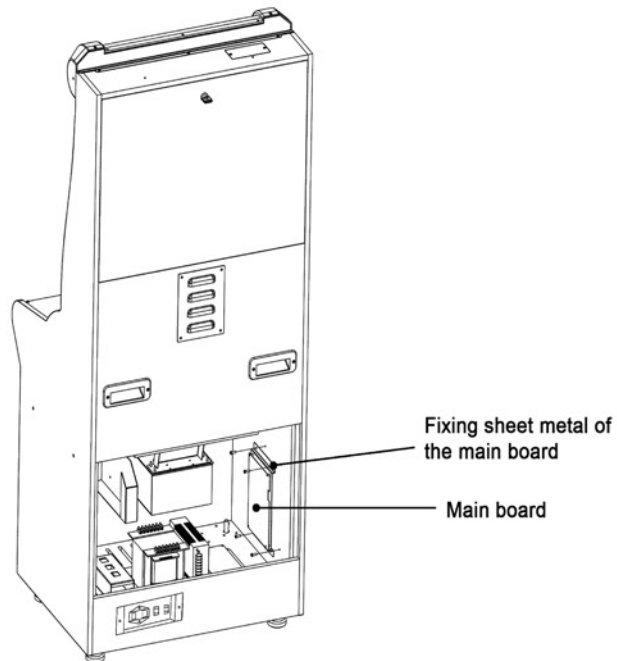



## 6. Internal hardware repair & replacement (AMP board, power supply, transformer and power inlet)

Step 1: Remove the back door of the machine by using a key.

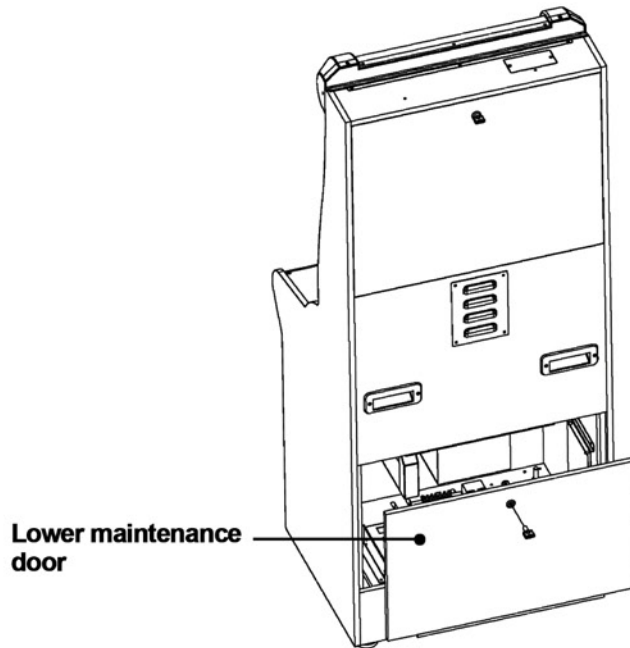

Step 2: Remove M3 screws to replace or repair the fixing wooden board.

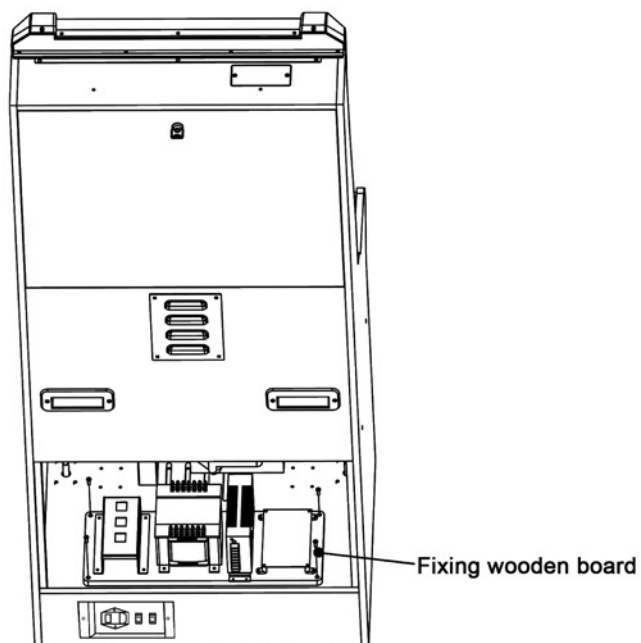



## Internal hardware descriptions:

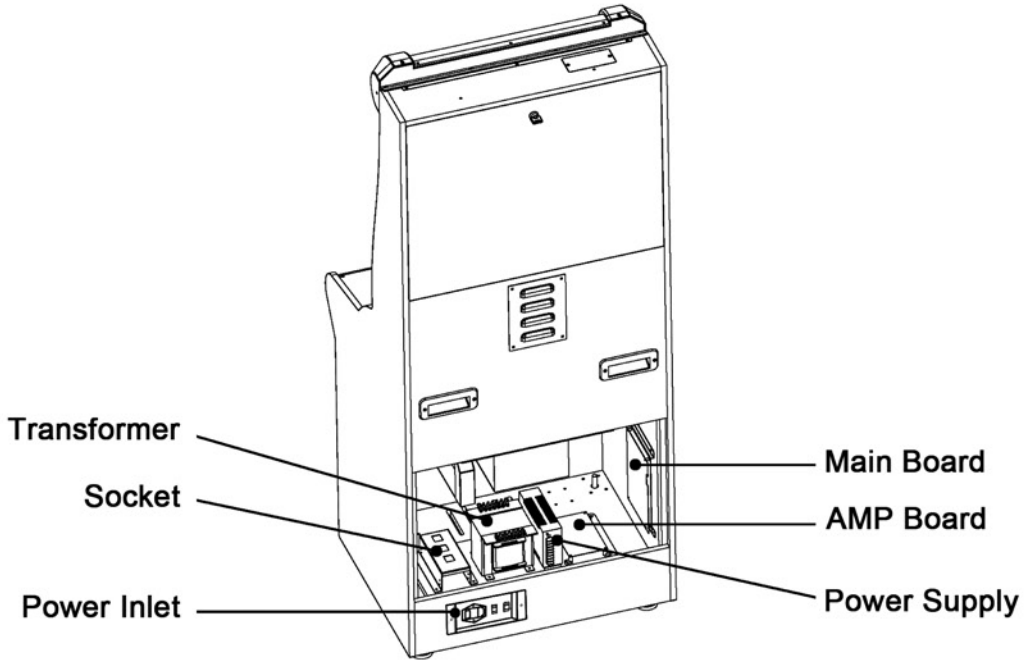

## Power inlet descriptions:

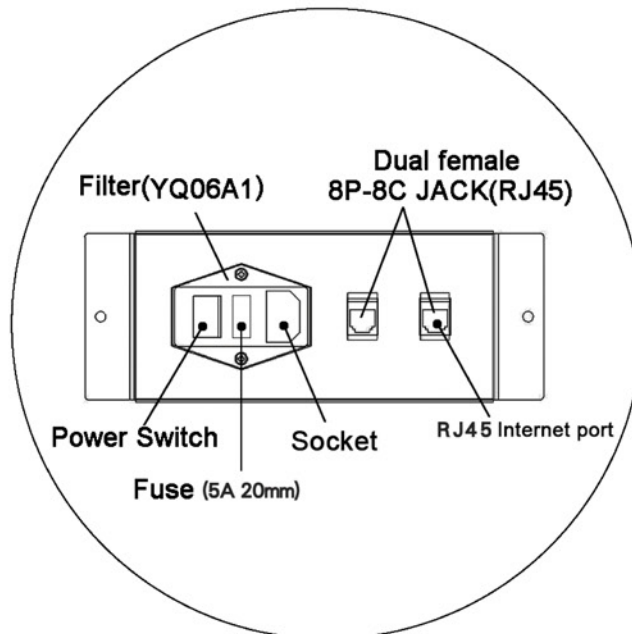





## 7. Linked machine assembly

Set up the linked machines and fasten them with wing screws from the side of machines.

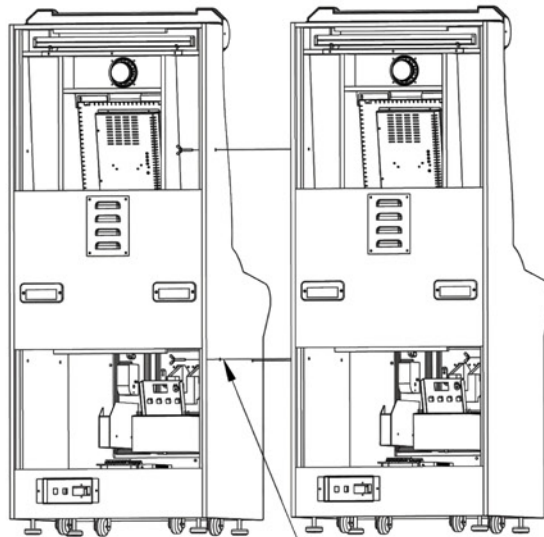

Fasten with wing screws

## 8. Linked light box assembly

Step 1: Lift the light box and push it to the groove.

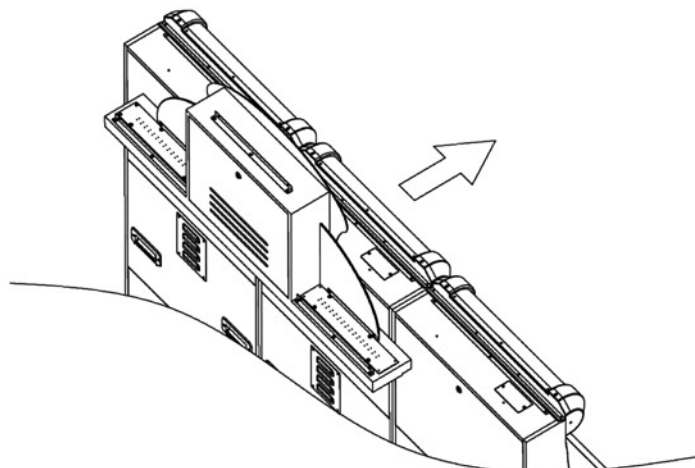

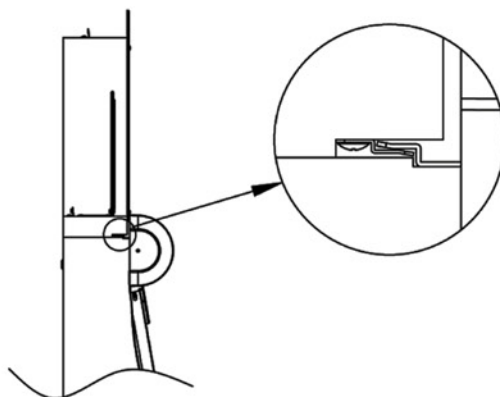

Step 2: Fasten with two M5 screws.

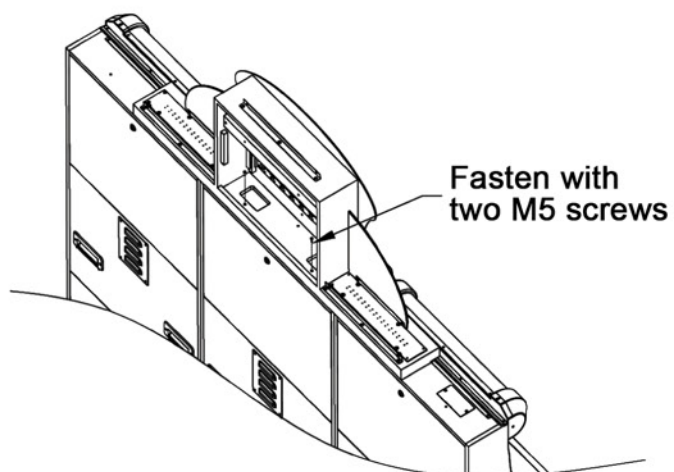

## 9. Decoration signboard assembly

Install the signboard on the light box and fasten with six M5 screws.

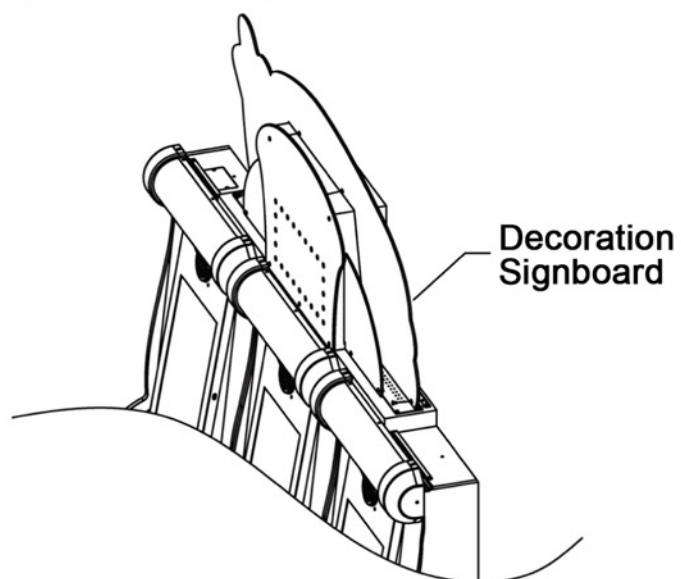



## 10. Central signboard light replacement

Remove the light box maintenance door to replace the light parts on the linked signboard.

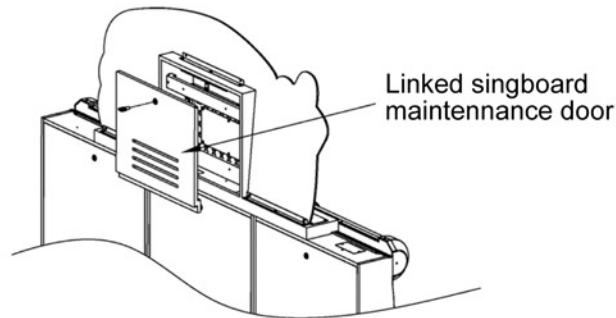

- Fluorescent light repair: replace the used light tube with a new one.

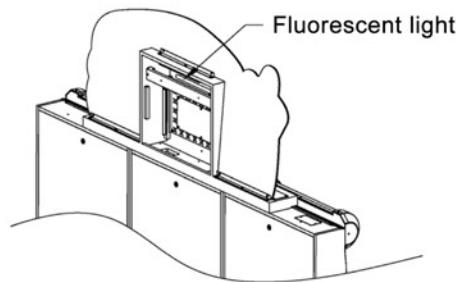

- LED replacement

Step 1: Remove the linked light box maintenance door and remove Four M5 screws on the sheet metal of the central light box and remove the signal cable.

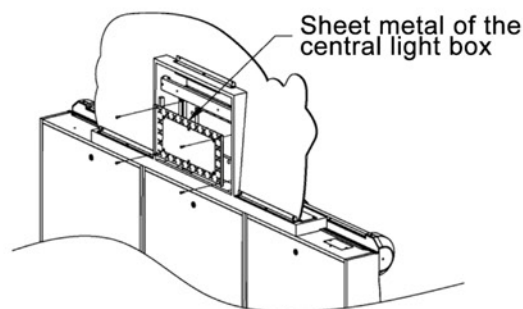



Step 2: Remove the LED light mask and then the LED light to replace a new one.

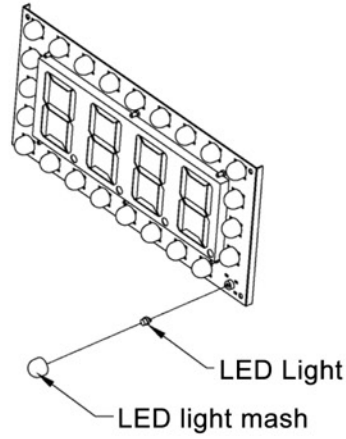

- Seven-segment display replacement

Remove the light box maintenance door, four M5 screws on the sheet metal of the central light box and the signal cable. Remove four M5 screws that fix sheet metal and the display so as to complete replacement.

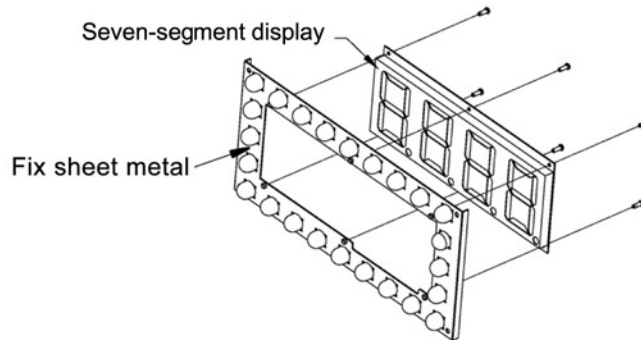



## 11. Left/Right fluorescent light tube replacement

Step 1: Remove four M5 screws inside the acrylic of the fluorescent light.

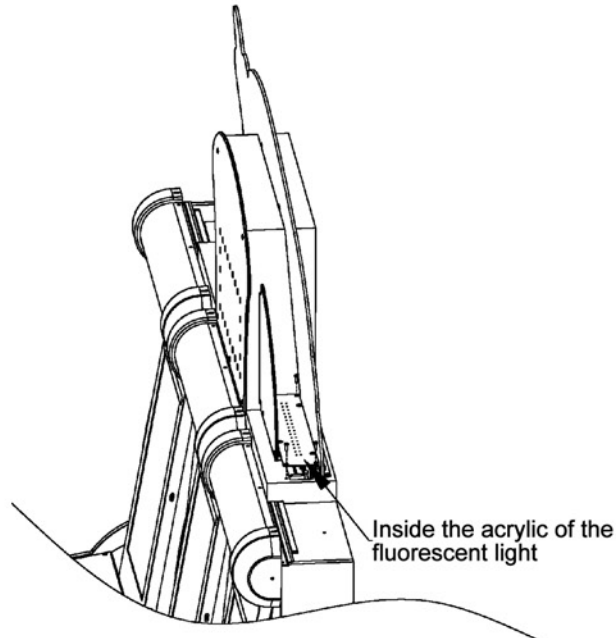

Step 2: Replace the used light tube with a new one.

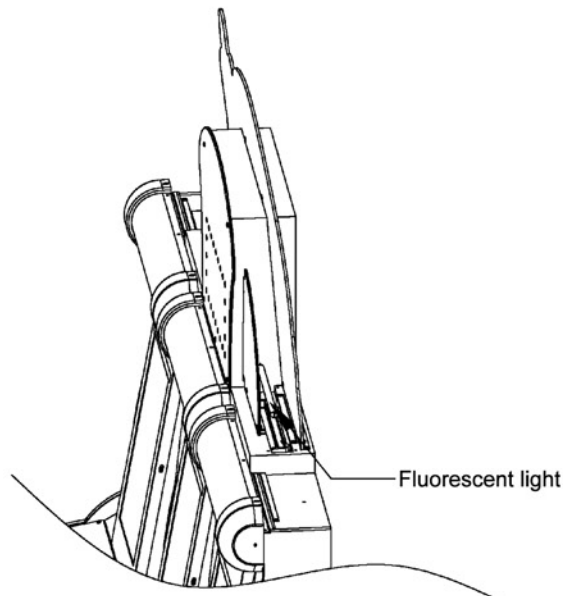



# 4. About the game

## 4.1 Game introduction

---

『Monkey Paradise』 is a ticket game. Inserting coins, players may start entering the game screen. By pressing the left/ right button, players may control the monkey to play the game and win tickets.



This game provides three versions of roles playing for selection. The selection of the roles may be done by using the DIP switch on the board; however, please note that the Server machine (No. 1) does not apply this function.



This game is basically a linked mode game. The linked mode increases the chance of ticket-out rate. When players enter the challenge pass, the chance of winning link bonus is higher. Under the Game Setting, if the Ticket No. Per Coin and Coin Rate are set to be high, the chance of winning is higher.



## 4.2 How to play

### Game screen description

The basic play method is described in the following:

<p>1.Insert coins to enter the game.</p>	
<p>2.Entering the main game screen, use the Left/Right buttons to play the game. Press Down key and monkey climbs up. The faster you press the buttons, the quicker the monkey climbs.</p>	



3. Aim at coconut! Press the Left/ Right button to jump and catch coconut.



4. If catching Golden coconut and entering Bonus Stage, in Bonus Stage use button to shoot the special balloon and win the Jackpot.









# 5. Operator menu

## 5.1 How to use Operator Menu

---

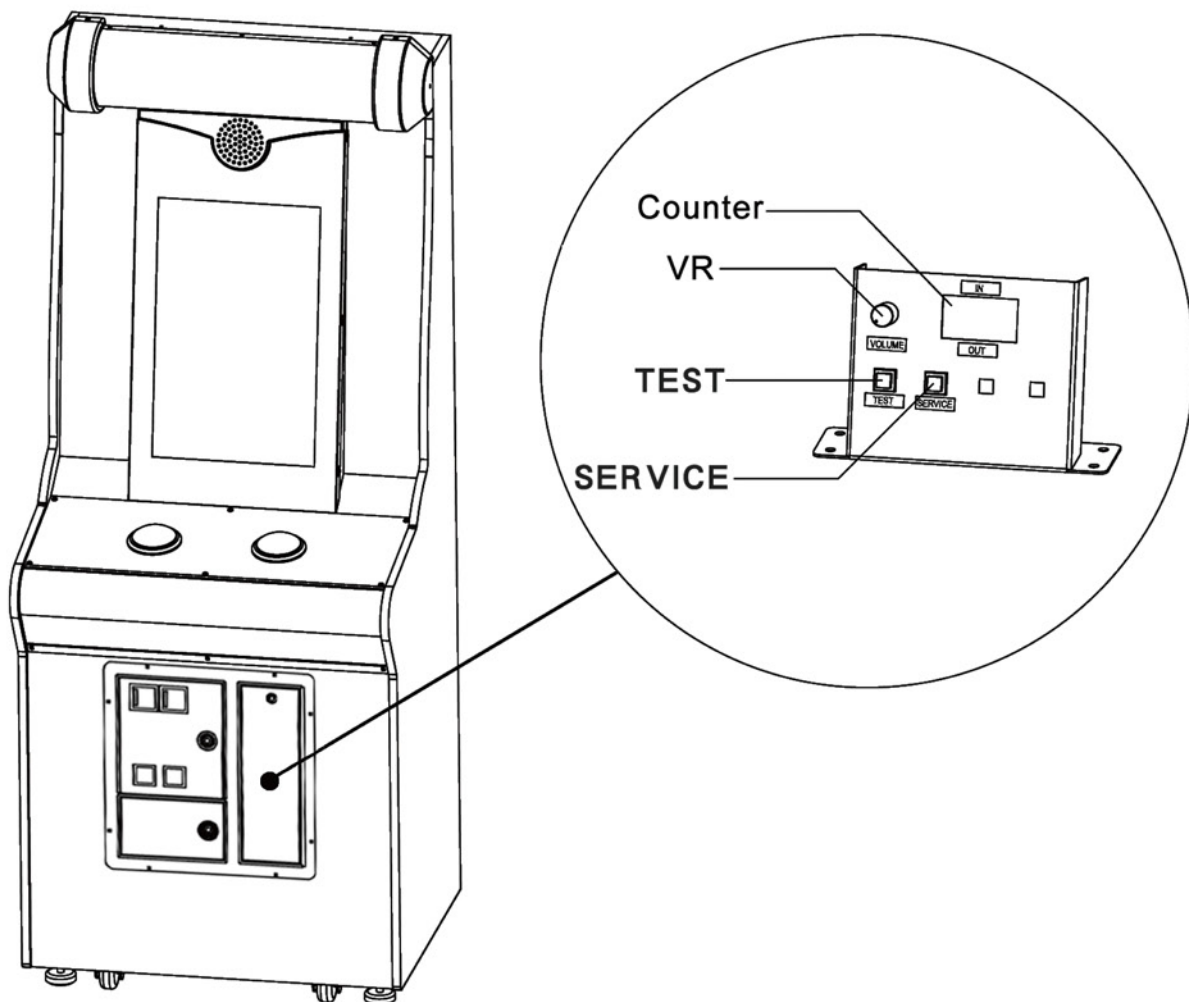
Press the Test Key to enter 『Operator Menu』 .





『Operator Menu』 allows operators to check game details and operation information. Under 『System Setting』, operators can define settings. For details about 『Operator Menu』, please refer to the instructions on the left down corner of the screen.

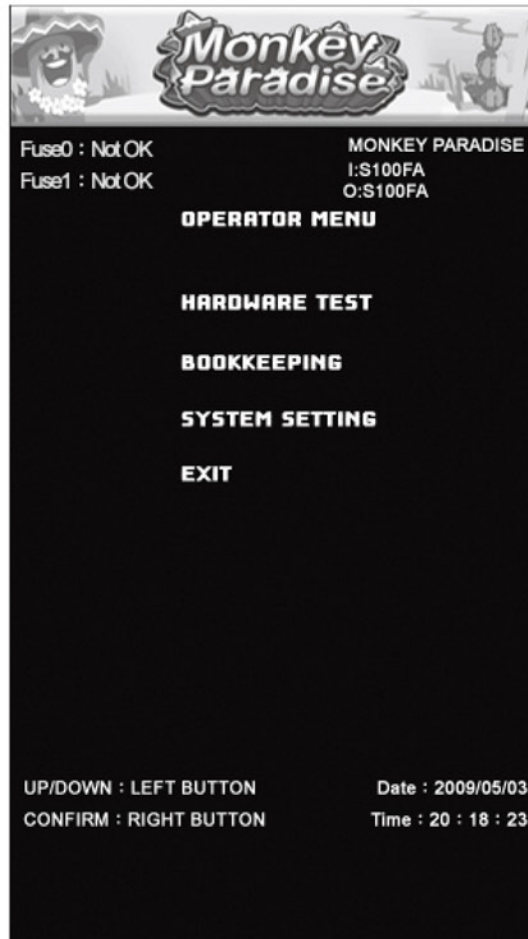

The following describes items under 『Operator Menu』 :

- 『Hardware Test』 : test machine hardware functions.
- 『System Setting』 : adjust game setting, machine password, machine time and so on.
- 『Exit』 : go back to operating status.



## 5.2 Hardware Test

『Hardware Test』 allows users to test if the machine function normally. Under 『Operator Menu』, select 『Hardware Test』 and confirm by pressing Right Button.

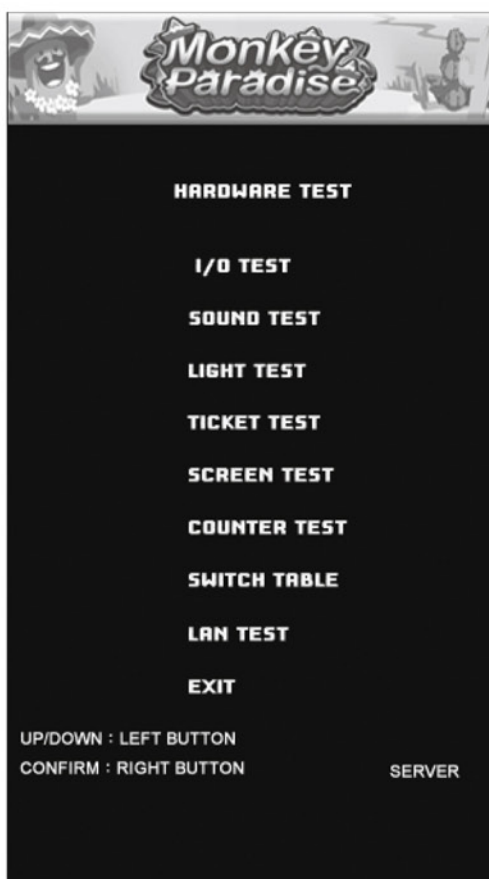

『Hardware Test』 provides the following settings:

- 『I/O Test』 : tests if the input devices function normally.
- 『Sound Test』 : tests if the sound can be played normally.
- 『Light Test』 : tests if the light is lit normally.
- 『Ticket Test』 : tests if tickets are given out successfully.
- 『Monitor Test』 : tests if the display functions normally.
- 『Counter Test』 : tests if the coin/ticker counter works normally.
- 『Switch Table』 : provides setting status information.
- 『Lan Test』 : check the machine connection status.
- 『Exit』 : go back to 『Operator Menu』 .



## 5.2.1 I/O Test

---

This allows users to test the machine's input devices and check if they function normally. Under 『Hardware Test』, select 『I/O Test』 and confirm by pressing Right Button.

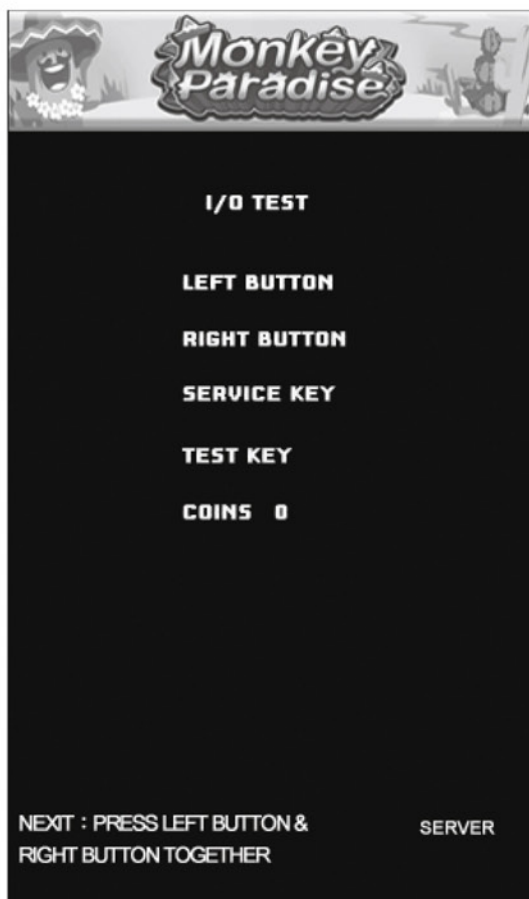

Under 『I/O Test』, users can test functions of the keys and coin slot.

- 『Key Test』 : Testing the keys, it's corresponding item on the screen flickers if the device function successfully.
- 『Coin Slot Test』 : Insert coins and the counter accumulates the number to the maximum of 999.

Exit: Go back to 『Hardware Test』 by pressing Left Button and Right Button simultaneously.



## 5.2.2 Sound Test

---

This allows users to test the audio output of the machine. Under 『Hardware Test』, select 『Sound Test』 and confirm by pressing Right Button.

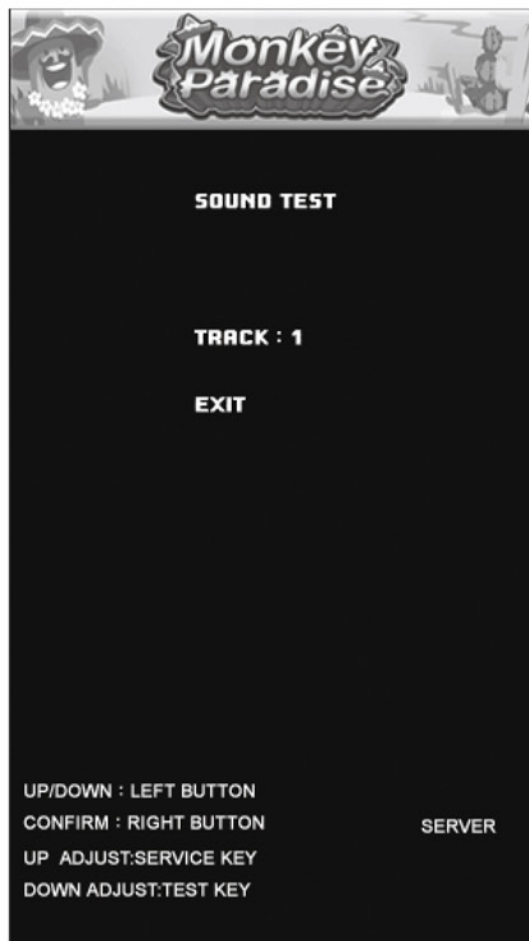

Entering the test screen, select piece of music using Test Key and Service Key and confirm to play the sound by pressing Right Button.

Exit: Press Left Button to exit and Right Button returning to 『Hardware Test』



## 5.2.3 Light Test

---

This allows users to test if the machine's light functions normally. Under 『Hardware Test』, select 『Light Test』 and confirm by pressing Right Button.



Entering the test screen, select 『Auto Test』 to start running the 『Light Test』 automatically whereas select 『Select Test』 to go to the specific light and test its function.

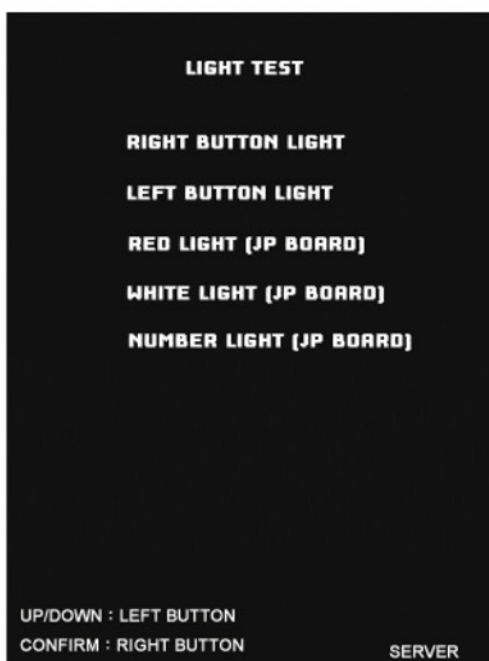

Exit: Press Left Button to exit and Right Button returning to 『Light Test』 screen.



## 5.2.4 Ticket Machine Test

---

This allows users to test if the ticket machine gives out tickets successfully. Under 『Hardware Test』, select 『Ticket Test』 and confirm by pressing Right Button.



Entering the testing screen and press Right Button to start testing. The screen will display OK if the machine gives five tickets successfully;

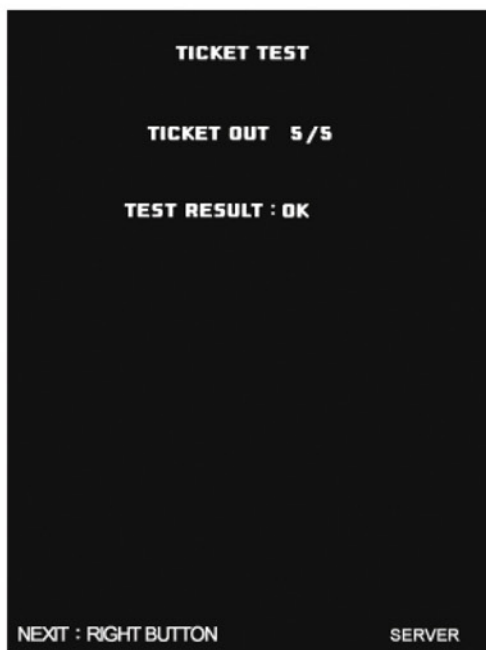



Otherwise, it displays ERROR if the machine cannot give out five tickets successfully.

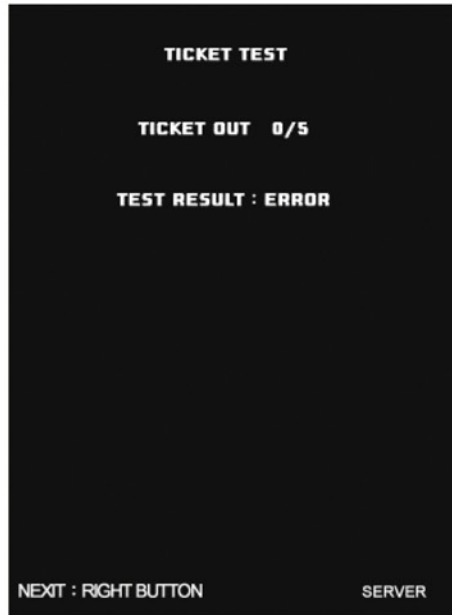

Exit: Press Right Button to go back to 『Hardware Test』.

## 5.2.5 Screen Test

---

This allows users to run a preliminary test of the machine's monitor, checking if the visual output functions normally. Under 『Hardware Test』, select 『Screen Test』 and confirm by press Right Button. Entering the screen, users may test if the screen displays normally by pressing Left/Right Button.

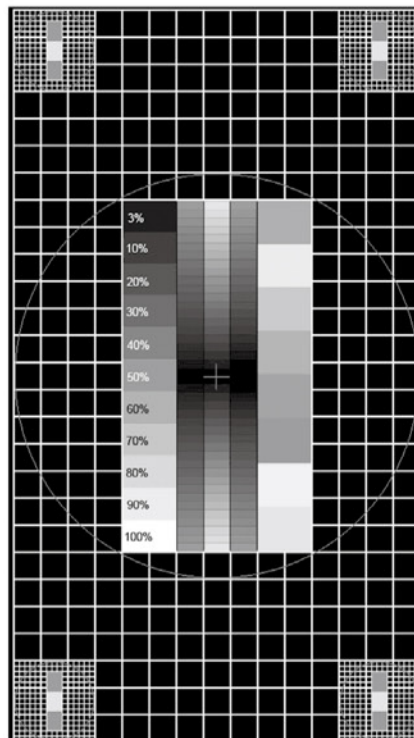





## 5.2.6 Counter Test

This allows users to test the coin channel meter, ticket meter and coin counter and see if they function normally. Under 『Hardware Test』, select 『Counter Test』 and confirm by pressing Right Button.

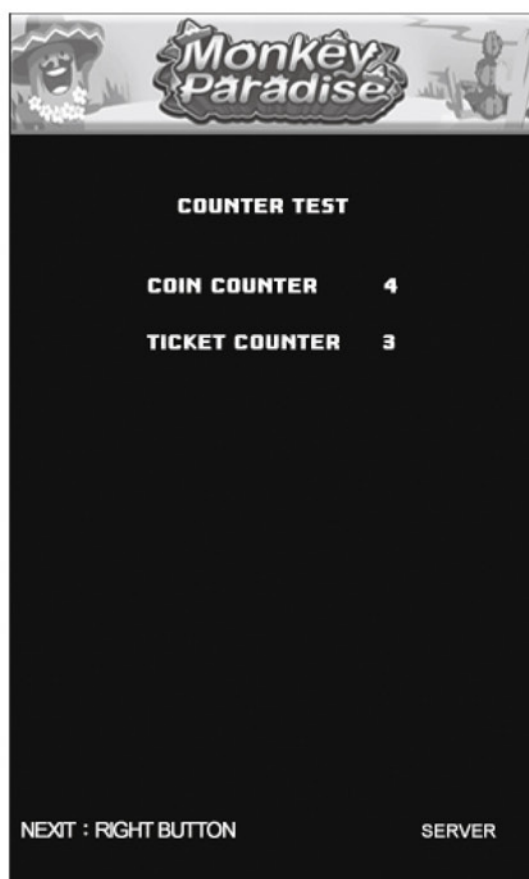

Entering the screen, coin counter and ticket counter will be tested automatically. The number of tests will also be shown on the screen. Please check if the number on the meter matches the number displayed on the screen. If they are identical, the meter functions normally. If not, the meter has problems.

Exit: Press Right Button to go back to 『Hardware Test』.



## 5.2.7 Switch Table

---

This allows users to check DIP Switch Settings. Under 『Hardware Test』, select 『Switch Table』 and confirm by pressing Right Button. Entering the screen, users may check the settings.



Exit: Press Right Button to go back to 『Hardware Test』 .



## 5.2.8 Lan Test

This allows users to verify the number of link machines. Under 『Hardware Test』, select 『Lan Test』 and confirm by pressing Right Button. Entering the screen, users may check the link status.

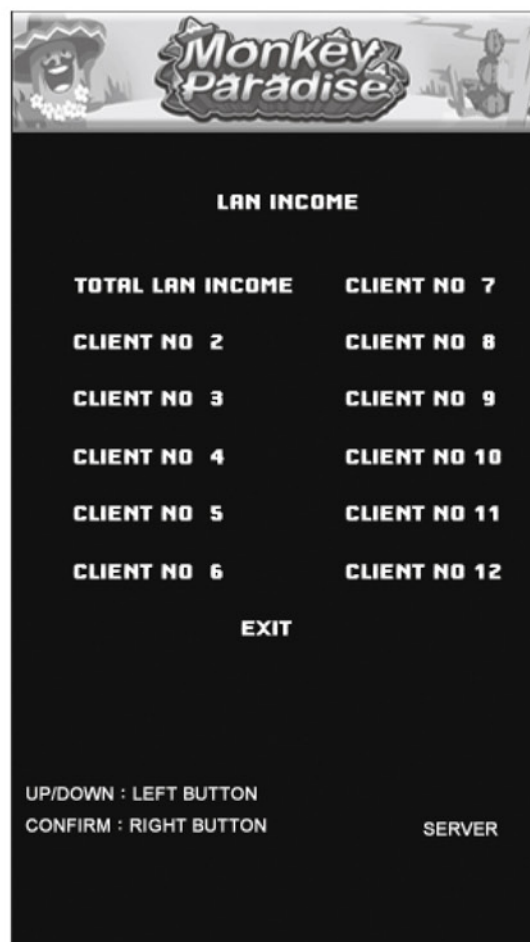

Exit: Press Right Button to go back to 『Hardware Test』.



## 5.3 System Setting

---

This allows users to define various 『Game Setting』. Under 『Operator Menu』, select 『System Setting』 and confirm by pressing Right Button. To use this feature, you are prompted to enter a combination of password. With correct input, you are permitted to enter 『System Setting』; otherwise, the system will return to 『Operator Menu』.

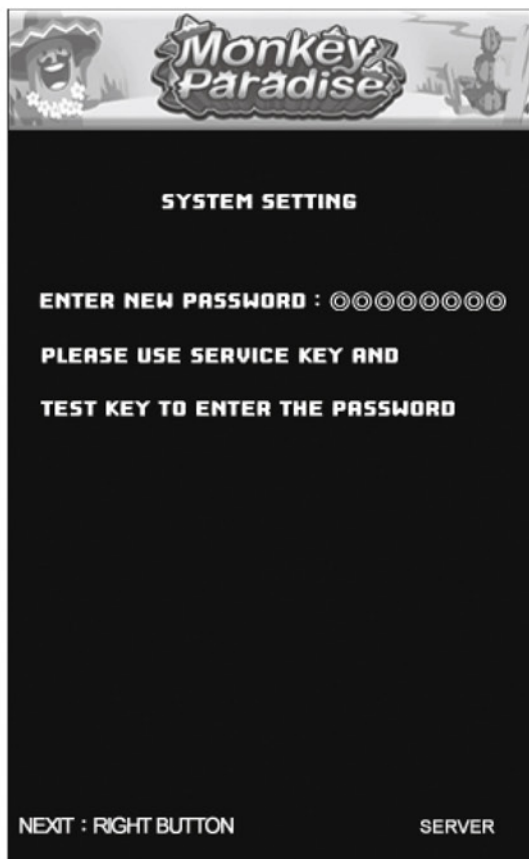

The default password is to press Test Key for eight times.



With correct entry of password, you may select to enter 『System Settings』 or define a new password.

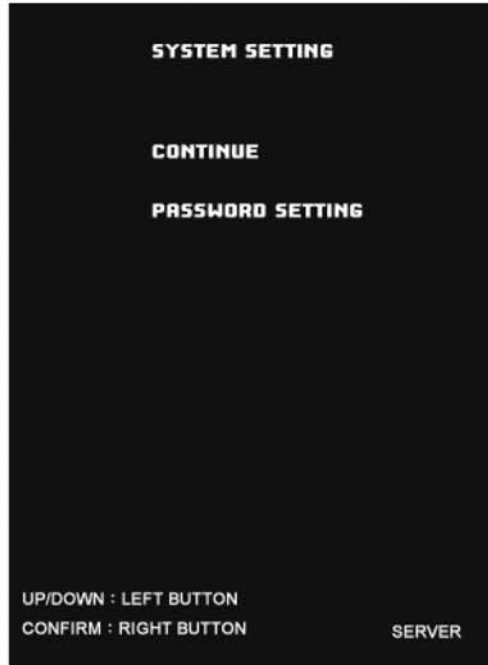

Under Password Setup, you are prompted to enter a new password and enter again to confirm it.

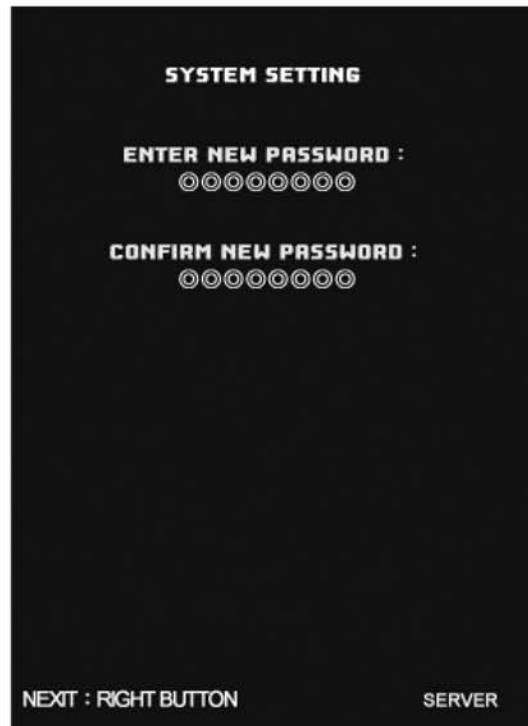



If the two passwords are identical, a success message is displayed and you may start using the new password from the next time.



If the two passwords are not identical, an error message is displayed and the screen goes directly back to 『System Setting』 .

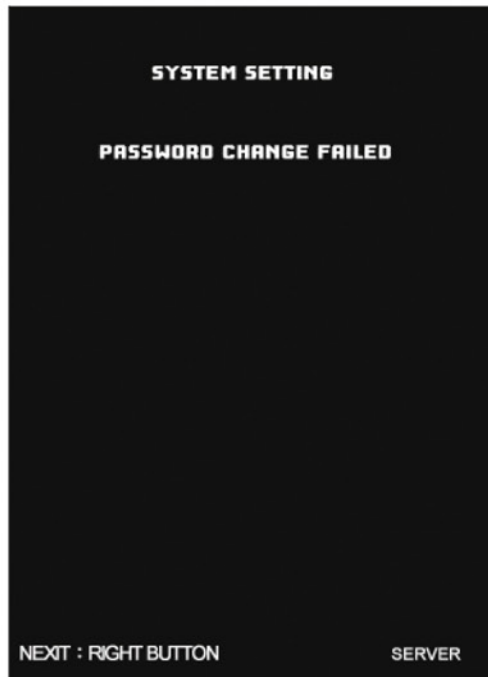



The following describes items under 『System Setting』 :

- 『Game Setting』 : allows users to adjust various game settings.
- 『Time Setting』 : allows users to set the machine time.
- 『System Reset』 : allows users to restore the system data to default values.
- 『Exit』 : Go back to 『Operator Menu』 .



Note: Various game settings under 『System Setting』 are only available from the Server machine.



## 5.3.1 Game Setting

This allows users to adjust different 『Game Setting』. Press Left/Right Button to go to the desired item and press Test Key and Service Key to change the 『Game Setting』.

GAME SETTING	
COIN RATE	1COIN/1CREDIT
FREE PLAY	NO
1CREDIT/AVE.TICKET	15
1CREDIT/MERCY TICKET	4
DEMO VOLUME	3
GAME VOLUME	3
EXIT	
SAVE & EXIT	
UP/DOWN : LEFT BUTTON	
CONFIRM : RIGHT BUTTON	
UP ADJUST:SERVICE KEY	
DOWN ADJUST:TEST KEY	
SERVER	

The following describes items under 『Game Setting』 :

- 『COIN RATE』 : adjusts the coin number to start a game.
- 『FREE PLAY』 : selects to turn on or off the free game feature.
- 『1CREDIT/AVE.TICKET』 : the average number of tickets given out per coin.
- 『1CREDIT/MERCY TICKET』 : the number of mercy tickets given out per coin.
- 『DEMO VOLUME』 : Adjust the volume of the demo music.
- 『GAME VOLUME』 : Adjust the volume of music during a game.
- 『EXIT』 : Make no changes to the 『Game Setting』 and leave this menu screen.
- 『SAVE&EXIT』 : Save the new 『Game Setting』 and then exit this menu screen.

Game Setting provides the following adjustment features:

Item	Values	Default Value
Coin Rate	1, 2, 3, 4	1 per game
Free Play	Yes/No	No
1CREDIT/AVE.TICKET	5~25	10
1CREDIT/MERCY TICKET	0~15	3
DEMO VOLUME	0~8	3
MUSIC VOLUME	0~8	2



Note: Adjusting 『COIN RATE』 and 『1CREDIT/AVE.TICKET』 under 『Game Setting』 will result in system reset.





## 5.3.2 Time Setting

This allows users to change the system time of the machine, which is only available from the Server machine. Under 『System Setting』, select 『Time Setting』 and confirm by pressing Right Button. Press Left/Right Button to go to the desired setting item and press Test and Service Key to set the value.



Items to be adjusted include Year, Month, Day, Hour, Minute and Second. After setting Second, press Right Button to confirm to return to 『System Setting』 and save the new settings at the same time.



### 5.3.3 System Reset

---

This feature allows users to restore the system data to its default value. Under 『System Setting』, select 『System Reset』 and confirm by pressing Right Button. Under 『System Reset』, you are prompted to confirm the action. Select Yes or No by using Left Button and confirm your selection by pressing Right Button.

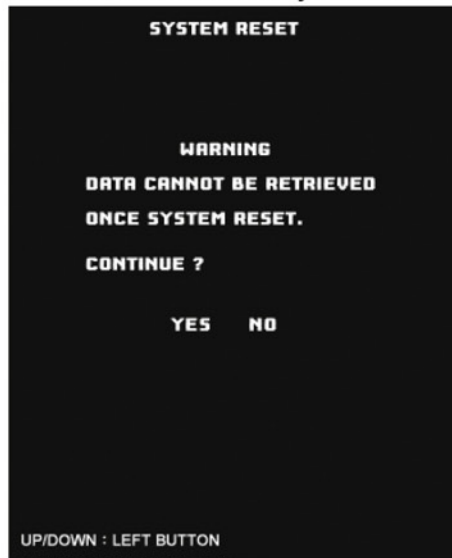

Select 『Yes』, the system data will be deleted and the screen shows a message that System has restored to Default values.

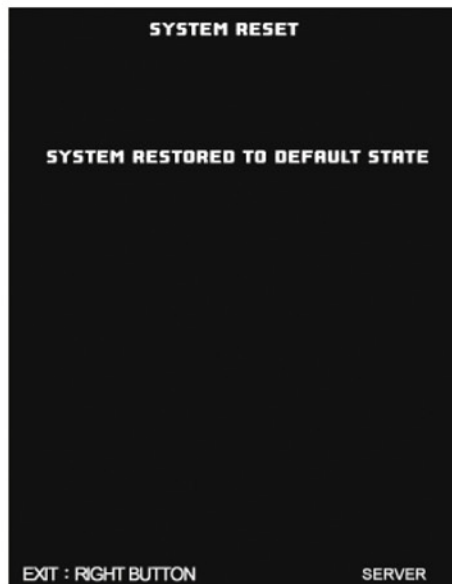

※ Please note that once the system data is deleted, it can never be retrieved.

Select 『No』 to go directly back to 『Operator Menu』 without making any changes to the 『System Setting』.



# 6. Q&A Troubleshooting

Problem	Troubleshooting
A · Buttons or Button light fail to function.	<ol style="list-style-type: none"><li>1.Refer to page 34 to run the test and see if the Button works normally.</li><li>2.Restart the machine.</li><li>3.Please contact the local dealer if the above solutions are tried but fail to work.</li></ol>
B · Server and linked machines cannot be linked.	<ol style="list-style-type: none"><li>1.Make sure that wires are correctly connected.</li><li>2.Please check Link Settings in Quick Installation Guide to check if the DIP switch settings are correct.</li><li>3.Please restart the machine.</li><li>4.Reset the system from the Server machine.</li><li>5.Reset toggle switch for Server and linked machines.</li><li>6.Please contact the local dealer if the above solutions are tried but fail to work.</li></ol>
C · Ticket machine fails.	<ol style="list-style-type: none"><li>1.Refer to page 37 to run the test and see if the machine works normally.</li><li>2.After troubleshooting, press Service Key to continue giving out the remaining tickets. Shut down the machine and power on again can allow to finish the ticket-out action.</li><li>3.Before the problem is resolved, press any key allows to detect again if the machine fails. At this moment, if the power is shut down and restarted, the system will automatically check if the ticket machine works. Only when the problem is resolved, the system goes to the game status.</li><li>4.Please contact the local dealer if the above solutions are tried but fail to work.</li></ol>
D · No game music.	<ol style="list-style-type: none"><li>1.Refer to page 35 to run the test and see if the music sounds normally. Go to 『System Setting』, select 『Game Setting』 and check if the volume is turned down to the lowest.</li><li>2.Please contact the local dealer if the above solutions are tried but fail to work.</li></ol>



# 7. Repair & Maintenance

## 7.1 Clean-up & Maintenance

---

### Machine Clean-up

Clean the machine daily. Please clean the machine with a soft and dry clothes. It is recommended that the micro-fabric clothes (such as the clothes used to clean used to clean glasses) be used to clean the machine.



# Appendix: Machine Wiring Diagram

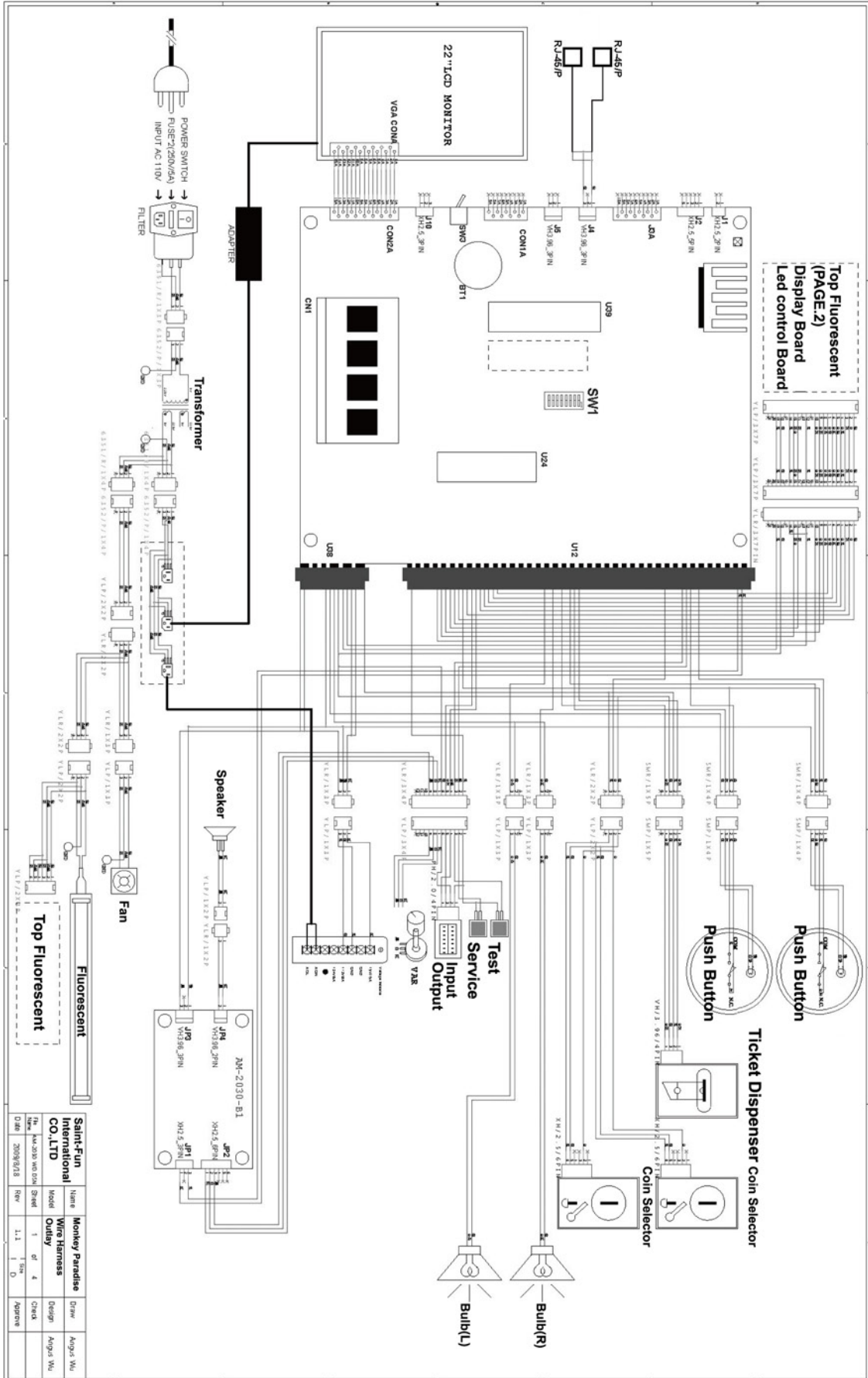

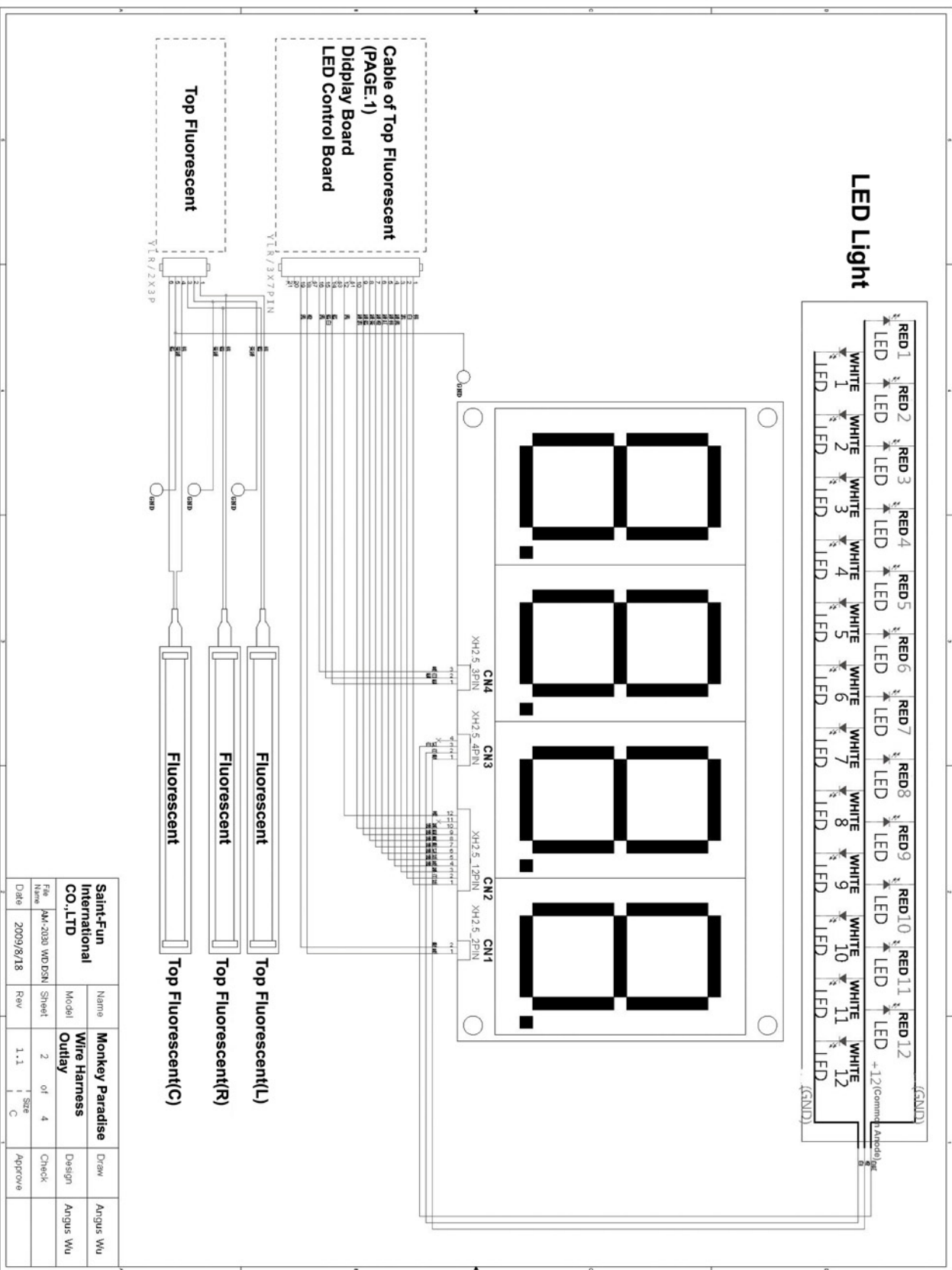

Saint-Fun International CO.,LTD		Monkey Paradise Wire Harness		Draw	Angus Wu
File Name	JAN-2008 WDDSN	Model	Outlay	Design	Angus Wu
Date	2009/8/18	Sheet	2 of 4	Check	
		Rev	1.1	Size	C
				Approve	

# Link Mode

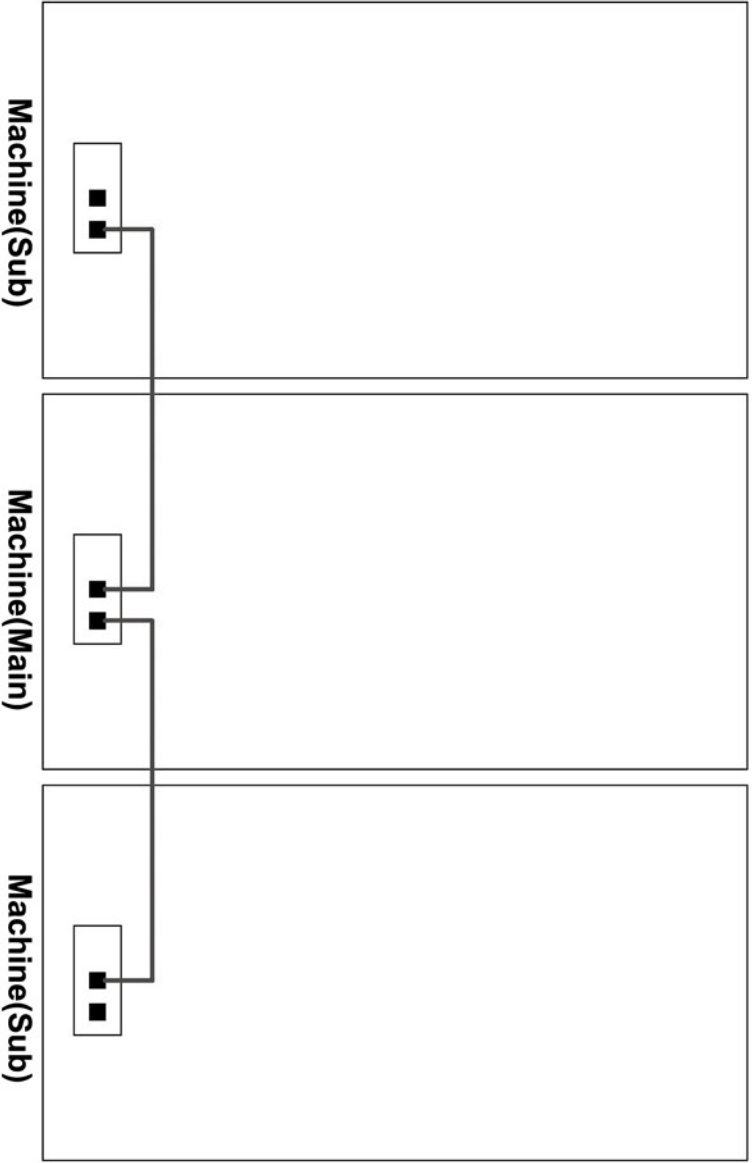

<b>Saint-Fun International CO.,LTD</b>		Name	<b>Monkey Paradise Wire Harness Outlay</b>		Draw	Angus Wu
		Model	<b>Wire Harness Outlay</b>		Design	Angus Wu
File Name	AM-2030 WD.DSN	Sheet	3	of	4	Check
Date	2009/8/18	Rev	1.1	Size	Custom	Approve



# 【Ground wiring Diagram】

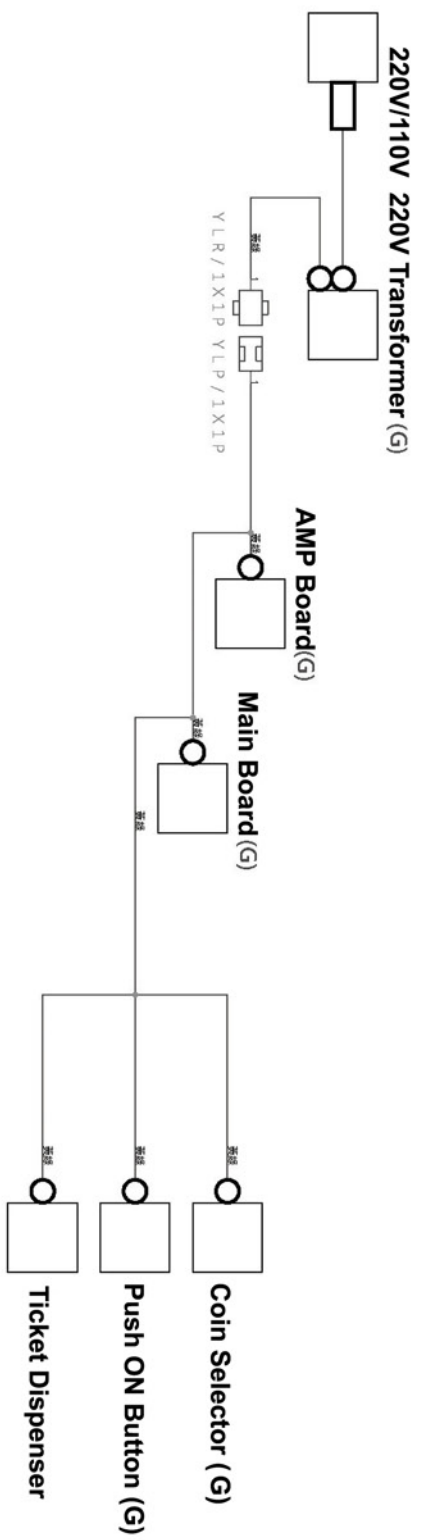

<b>Saint-Fun International CO., LTD</b>		Name	<b>Monkey Paradise</b>		Draw	Angus Wu
		Model	<b>Wire Harness Outlay</b>		Design	Angus Wu
File Name	AM-/2030 WDDSN	Sheet	4	of	4	Check
Date	2009/8/18	Rev	1.1	Size	B	Approve





# Monkey Paradise